

TOP VIEW

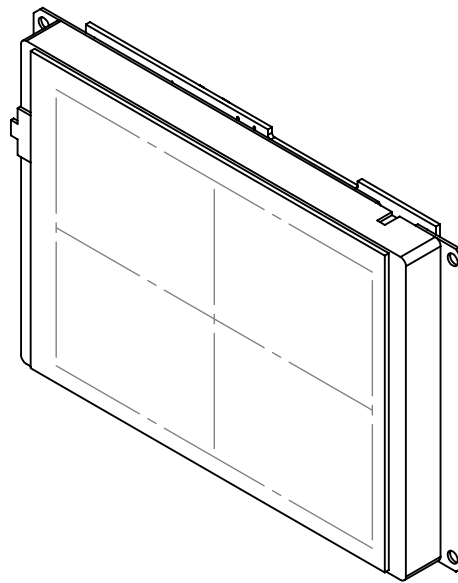

REVISIONS			
REV.	DESCRIPTION	DATE	APPROVED
A	Production Release.	10/14/2015	

FRONT VIEW

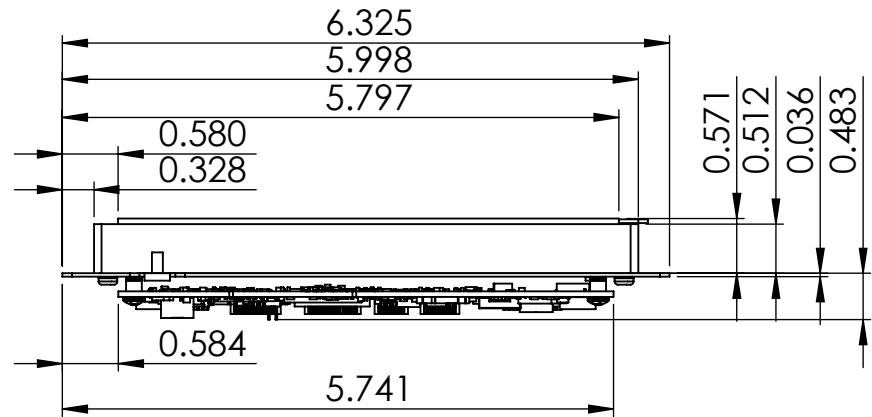
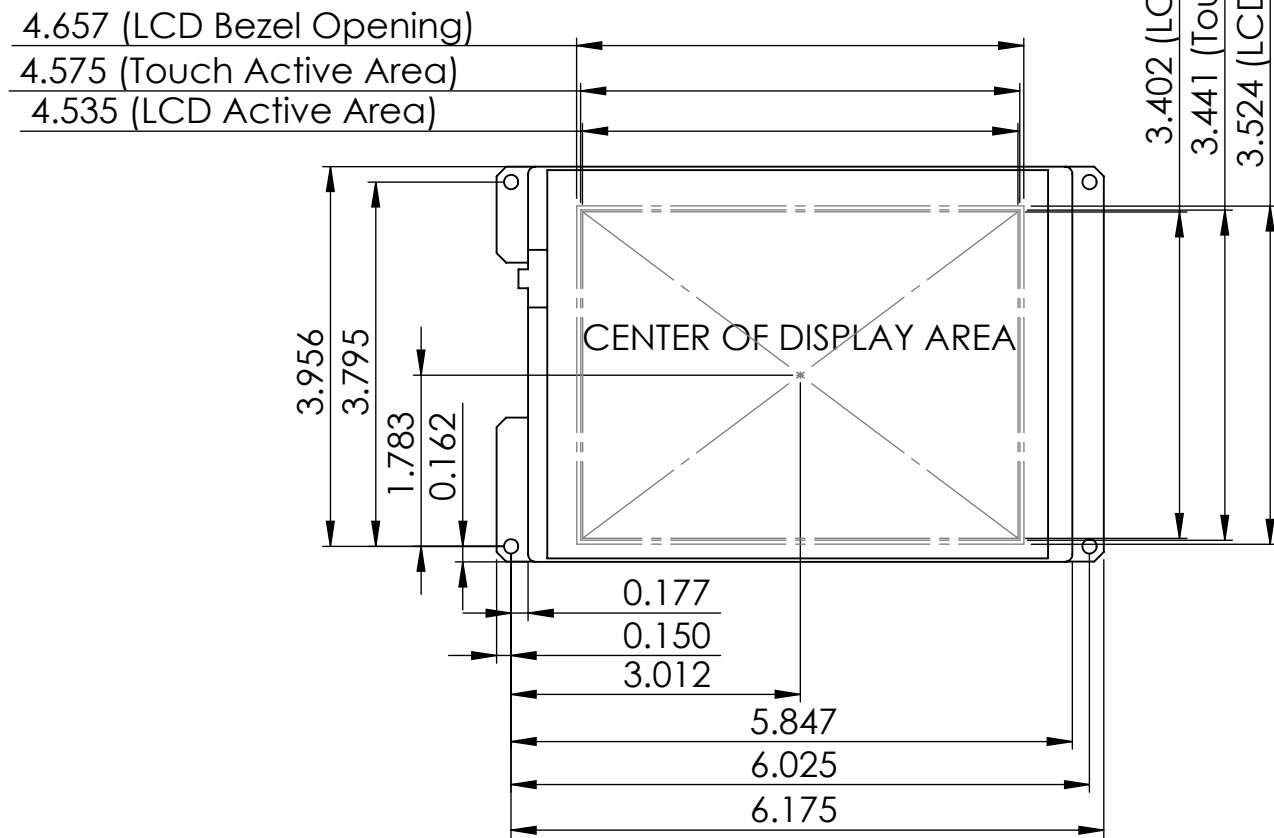

BACK VIEW

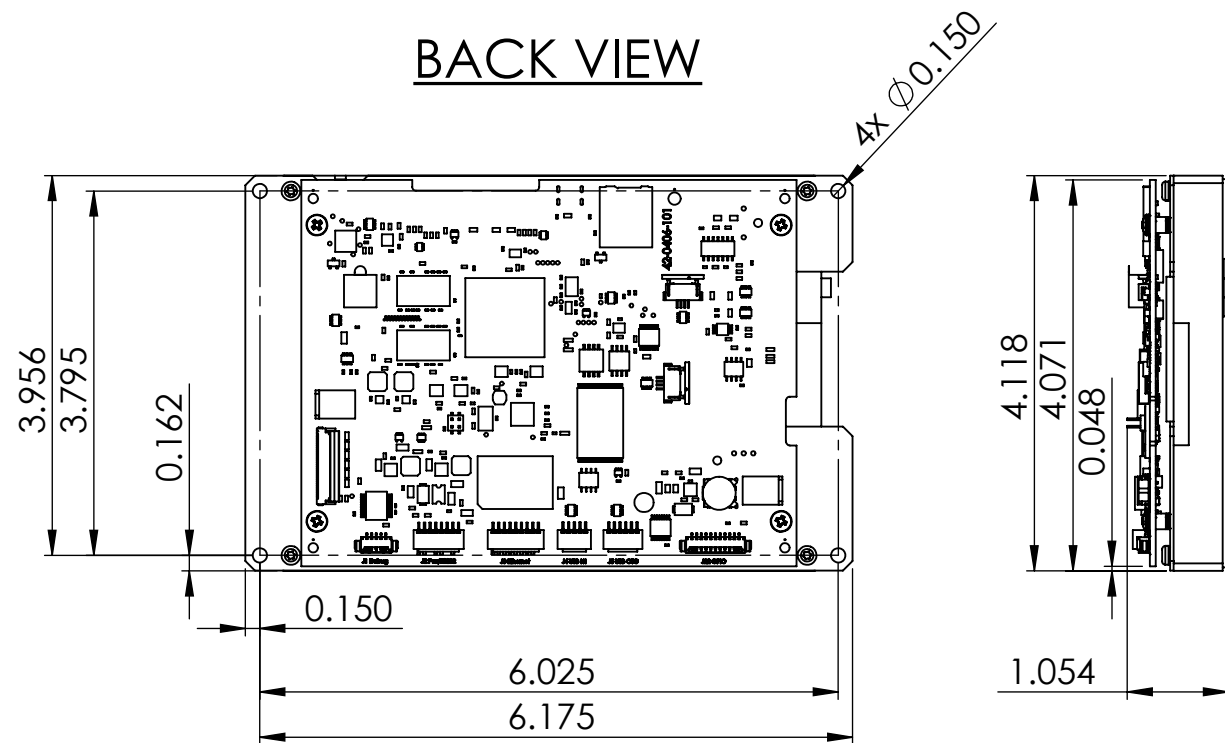

PROPRIETARY AND CONFIDENTIAL
 THE INFORMATION CONTAINED IN THIS DRAWING IS THE SOLE PROPERTY OF REACH TECHNOLOGY. ANY REPRODUCTION IN PART OR AS A WHOLE WITHOUT THE WRITTEN PERMISSION OF REACH TECHNOLOGY IS PROHIBITED.

UNLESS OTHERWISE SPECIFIED:		NAME	DATE	REACH TECHNOLOGY INC.
DIMENSIONS ARE IN INCHES TOLERANCES: FRACTIONAL ± ANGULAR: MACH ± BEND ± TWO PLACE DECIMAL ± THREE PLACE DECIMAL ±		DRAWN	B. Larson	
INTERPRET GEOMETRIC TOLERANCING PER:		CHECKED		TITLE: PRODUCTION MODULE, G2H2, 5.7" Evervision Parallel, Res Touch
MATERIAL SEE NOTES		ENG APPR.		Dwg No. DWG-51-0406-181
FINISH SEE NOTES		MFG APPR.		Rev. Edition A.1
NEXT ASSY	USED ON	Q.A.		SIZE Part No. B 51-0406-181
APPLICATION	DO NOT SCALE DRAWING	COMMENTS:		Rev A
			SCALE: 1:2	WEIGHT:
			SHEET 1 OF 1	