



晶采光電科技股份有限公司
AMPIRE CO., LTD.

SPECIFICATIONS FOR LCD MODULE

CUSTOMER	Reach Technology, part of Novanta
CUSTOMER PART NO.	34-0058-02
AMPIRE PART NO.	AM-320240NSMZQW-T87H
DATE	3/16/2023

Preliminary Specification

Formal Specification

AMPIRE CO., LTD.

**4F., No.116, Sec. 1, Xintai 5th Rd., Xizhi Dist., New Taipei
City221, Taiwan (R.O.C.)**

新北市汐止區新台五路一段 116 號 4 樓(東方科學園區 A 棟)

APPROVED BY	CHECKED BY	ORGANIZED BY
Patrick	Lawlite	Kokai

This Specification is subject to change without notice.

RECORD OF REVISION

Revision Date	Page	Contents	Editor
2023/3/7	-	New Release	Kokai
2023/3/16	4,22,23	Rename to AM-320240NSMZQW-T87H Update the drawing	

1 Features

5.7 inch Amorphous-TFT-LCD (Thin Film Transistor Liquid Crystal Display) module. This module is composed of a 5.7" TFT-LCD panel, a driver circuit and backlight unit.

- (1) Construction: 5.7" a-Si color TFT-LCD, White LED Backlight and PCB.
- (2) Resolution (pixel): 320(R.G.B) X240
- (3) Number of the Colors : 262K colors (R , G , B 6 bit digital each)
- (4) LCD type : Transmissive Color IPS TFT LCD (normally Black), **Anti-Glare polarizer.**
- (5) Interface: 33 pin
- (6) Power Supply Voltage: 3.3V single power input. Built-in power supply circuit.
- (7) Viewing Direction: All Direction.
- (8) PCB REV.D ;
- (9) 4 Wires Resistive touch panel.

2 Physical specifications

Item	Specifications	Unit
Display resolution(dot)	320 (W) x RGB x 240(H)	mm
Active area	115.2 (W) x 86.4 (H)	mm
Screen size	5.7(Diagonal)	mm
Pixel size	120 (W) x 360 (H)	um
Color configuration	R.G.B stripe	
Weight	T.B.D	mg
Backlight unit	LED	

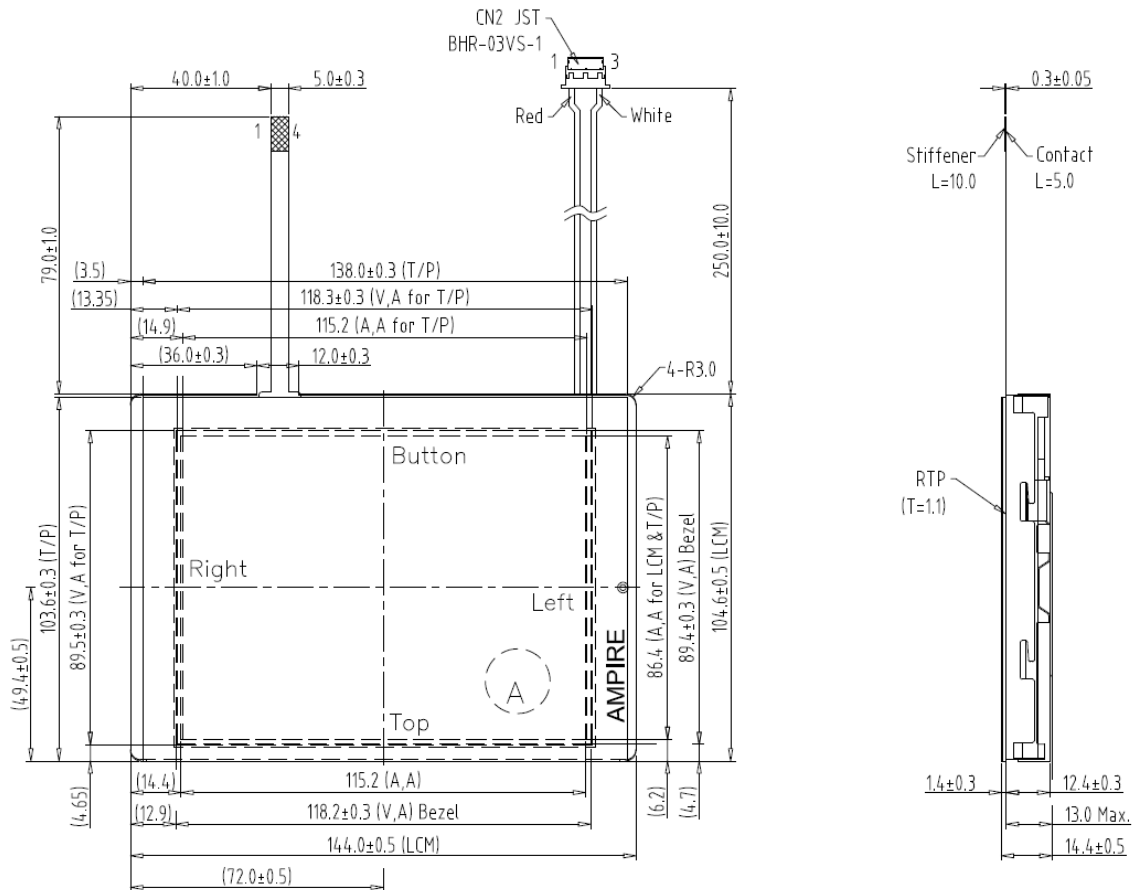

3 Electrical specification

3.1 Absolute max. ratings

3.1.1 Electrical Absolute max. ratings

Item	Symbol	Condition	Min.	Max.	Unit	Remark
Power voltage	VCC	VSS=0	-0.3	4.0	V	
Input voltege	V _{in}		-0.3	VCC+0.3	V	Note 1

Note1:Hsync, Vsync, ENAB, CK, R0~R5, G0~G5, B0~B5

3.1.2 Environmental Absolute max. ratings

Item	OPERATING		STORAGE		Remark
	MIN	MAX	MIN	MAX	
Temperature	-20	70	-30	80	Note2,3,4,5,7
Humidity	Note1		Note1		
Corrosive Gas	Not Acceptable		Not Acceptable		

Note1 : Ta <= 40°C : 85% RH max

Ta > 40°C : Absolute humidity must be lower than the humidity of 85%RH at 40°C

Note2 : For storage condition Ta at -30°C < 48h , at 80°C < 100h

For operating condition Ta at -20°C < 100h

Note3 : Background color changes slightly depending on ambient temperature. This phenomenon is reversible.

Note4 : The response time will be slower at low temperature.

Note5 : Only operation is guaranteed at operating temperature. Contrast , response time, another display quality are evaluated at +25°C

3.2 Electrical characteristics

3.2.1 DC Electrical characteristic of the LCD

Typical operating conditions (VSS=0V)

Item	Symbol	Min.	Typ.	Max.	Unit	Remark
Power supply	VCC	3.0	3.3	3.6	V	
Input Voltage for logic	H Level	$0.7 V_{CC}$	-	VCC	V	Note 1
	L Level	0	-	$0.3 V_{CC}$	V	
Power Supply current	ICC		45	55	mA	Note 2

Note1: Hsync, Vsync, DEN, DCLK, R0~R5, G0~G5, B0~B5

Note2: $f_v = 60\text{Hz}$, $T_a = 25^\circ\text{C}$, Display pattern : All Black

3.2.2 Electrical characteristic of LED Back-light

Parameter	Symbol	Min.	Typ.	Max.	Unit	Condition
LED voltage	V_{AK}	--	10.2	--	V	$I_{LED} = 240\text{mA}, T_a = 25^\circ\text{C}$
LED forward current	I_{LED}	--	240	--	mA	$T_a = 25^\circ\text{C}$
	I_{LED}	--	180	225	mA	$T_a = 60^\circ\text{C}$
Lamp life time		20,000	30,000	--	Hr	$I_{LED} = 240\text{mA}, T_a = 25^\circ\text{C}$

- The constant current source is needed for white LED back-light driving.

When LCM is operated over 60°C ambient temperature, the I_{LED} of the LED

back-light should be adjusted to 225mA max

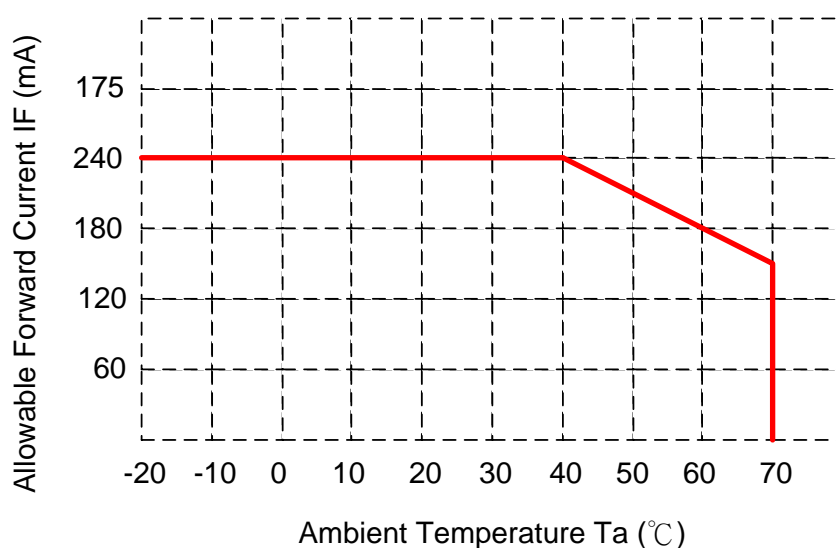

3.3 AC Timing characteristic of the LCD

3.3.1 RGB Timing condition

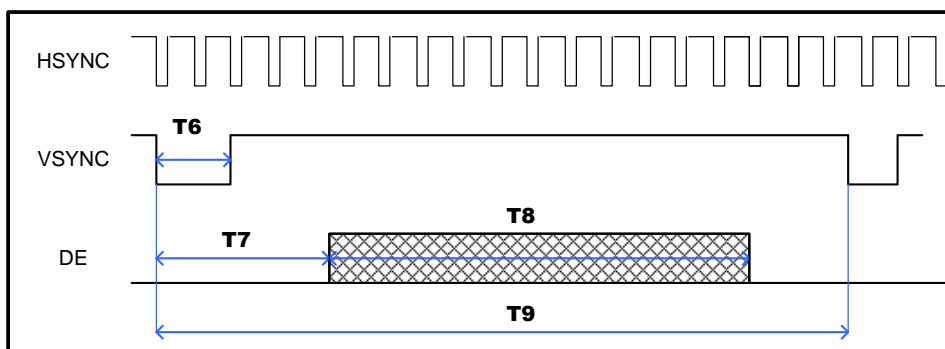
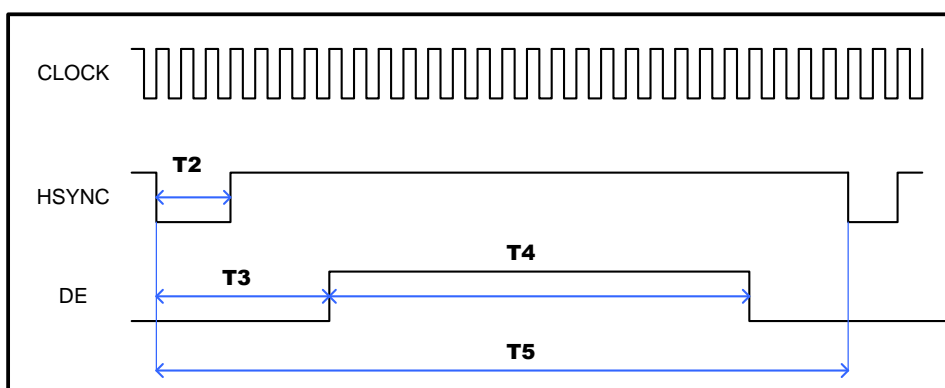
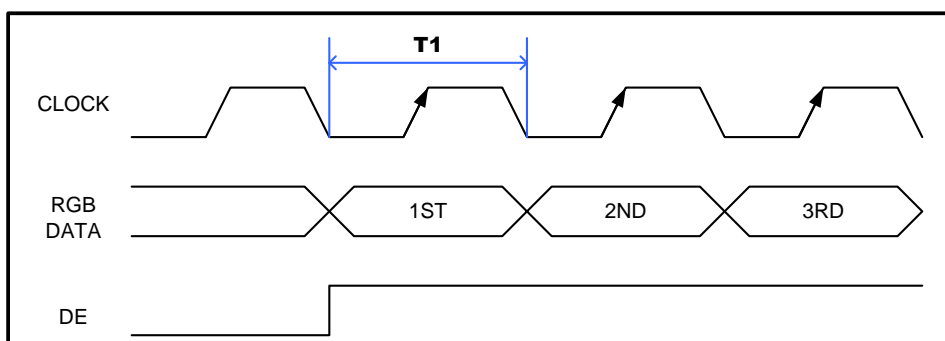

ITEM	SYMBOL	MIN	TYP	MAX	UNIT
Clock Frequency	1/T1	5	6	8	MHz
HSYNC Plus Wide	T2	2	4	43	clocks
HSYNC to DE	T3	3	43	43	Clocks
Horizontal Display Period	T4	320	320	320	Clocks
Horizontal total Period	T5	325	371	438	Clocks
VSYNC Plus Wide	T6	2	4	12	Lines
VSYNC to DE	T7	2	12	12	Lines
Vertical Display Period	T8	240	240	240	Lines
Vertical total Period	T9	244	260	289	Lines

SYNC - DE Mode	Input	Input	Input	Input
SYNC Mode	Input	Input	Input	GND
DE Mode	Input	GND	GND	Input

3.3.2 Power ON Sequence.

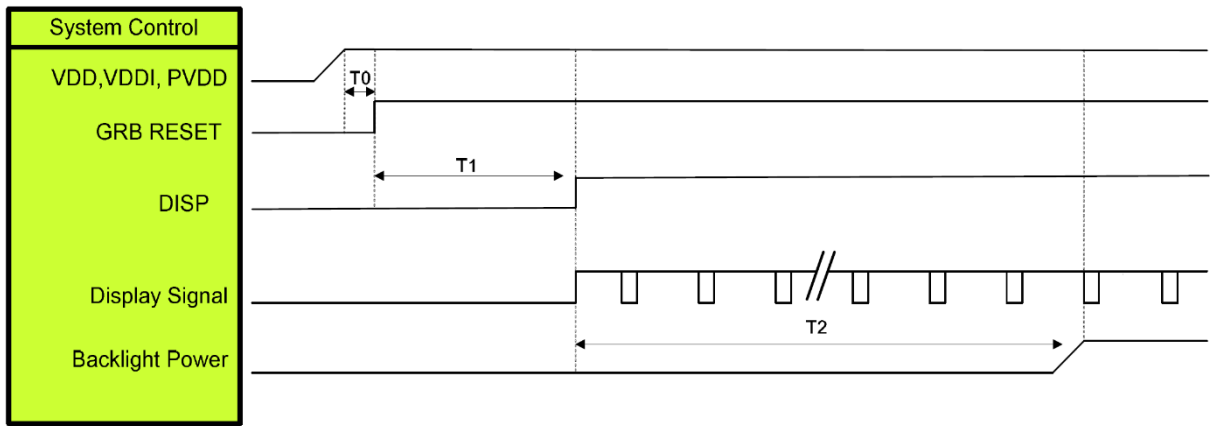

Symbol	Description	Min. Time	Unit
T0	System power stability to GRB RESET signal	0	ms
T1	GRB RESET= "High" to DISP="High"	10	ms
T2	Display Signal output to Backlight Power on	250	ms

Note: Display signal: DCLK; VSYNC; HSYNC; DE; R[5:0]; G[5:0]; B[5:0]

3.3.3 Power OFF Sequence.

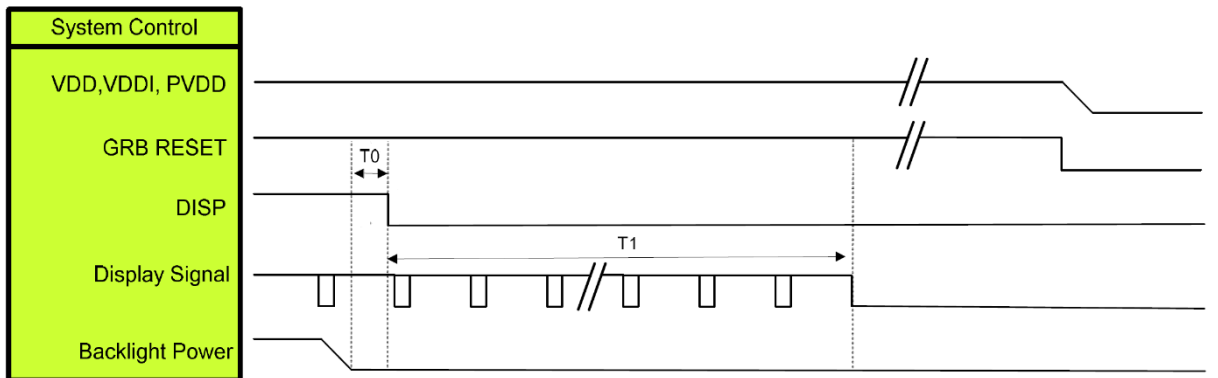

Symbol	Description	Min. Time	Unit
T0	Backlight Power off to DISP="Low"	5	ms
T1	DISP="Low" to IC internal voltage discharge complete	80	ms

Note: Display signal: DCLK; VSYNC; HSYNC; DE; R[5:0]; G[5:0]; B[5:0]

4 Optical specification

4.1 Optical characteristic of the LCD

Item		Symbol	Condition	Min.	Typ.	Max.	Unit	Remark
Response Time	Rise	T_r	$\Theta=0^\circ$	--	35	45	ms	Note 1,2,3,5
	Fall	T_f						
Contrast ratio		CR	At optimized viewing angle	700	1000	-		Note 1,2,4,5
Viewing Angle	Top		$CR \geq 10$	70	80	-	deg.	Note1,2, 5,6
	Bottom			70	80	-		
	Left			70	80	-		
	Right			70	80	-		
Brightness		Y_L	$I_{LED}=240mA,$ $25^\circ C$	450	560	-	cd/m^2	Note 7
Brightness Uniformity				75	--	--	%	Note 8
Red chromaticity		XR	$\Theta=0^\circ$ $\Theta=0^\circ$	Typ - 0.05	0.638	Typ + 0.05		Note 7 For reference only. These data should be update according the prototype.
		YR			0.312			
Green chromaticity		XG			0.278			
		YG			0.538			
Blue chromaticity		XB			0.147			
		YB			0.115			
White chromaticity		XW			0.312			
		YW			0.356			

() For reference only. These data should be update according the prototype.

Note 1: Ambient temperature= $25^\circ C$, and $I_{LED}=240 mA$. To be measured in the dark room.

Note 2: To be measured on the center area of panel with a viewing cone of 1° by Topcon luminance meter BM-7, after 10 minutes operation.

Note 3. Definition of response time:

The output signals of photo detector are measured when the input signals are changed from "black" to "white" (falling time) and from "white" to "black" (rising time), respectively. The response time is defined as the time interval between the 10% and 90% of amplitudes. Refer to figure as below.

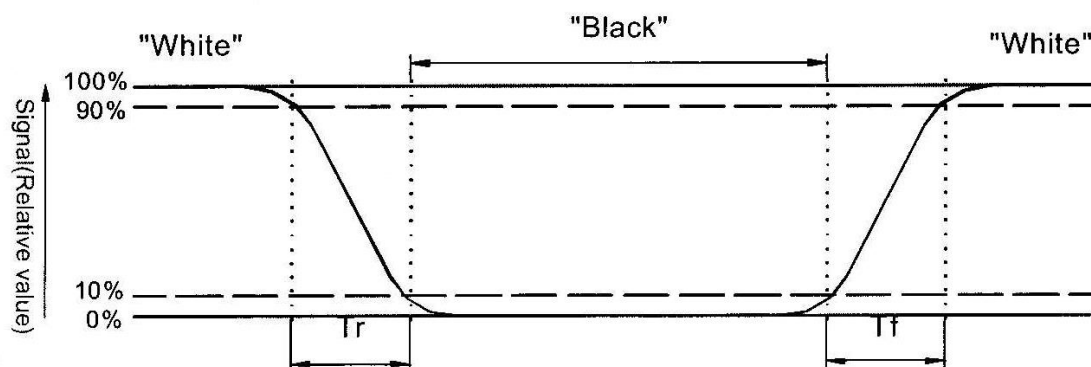

Note 4. Definition of contrast ratio:

Contrast ratio is calculated with the following formula.

$$\text{Contrast ratio(CR)} = \frac{\text{Photo detector output when LCD is at "White" state}}{\text{Photo detector Output when LCD is at "Black" state}}$$

Note 5: White $V_i = V_{i50} + 1.5V$

Black $V_i = V_{i50} + 2.0V$

“±” means that the analog input signal swings in phase with V_{COM} signal.

“ $\frac{-}{+}$ ” means that the analog input signal swings out of phase with V_{COM} signal.

V_{i50} : The analog input voltage when transmission is 50%. The 100% Transmission is defined as the transmission of LCD panel when all the Input terminals of module are electrically opened.

Note 6. Definition of viewing angle, Refer to figure as below.

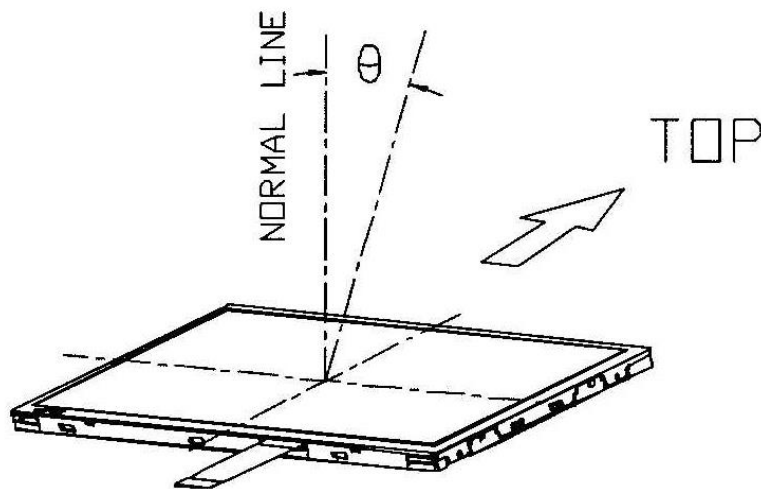

Note 7. Measured at the center area of the panel when all the input terminals of LCD panel are electrically opened.

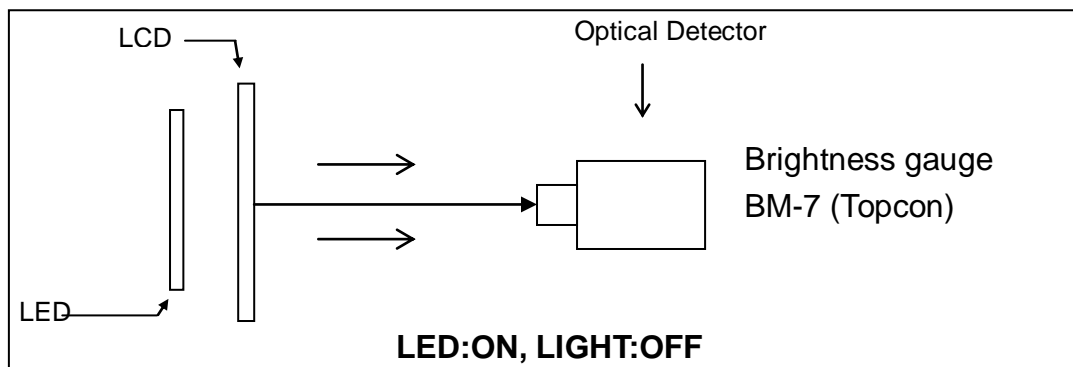
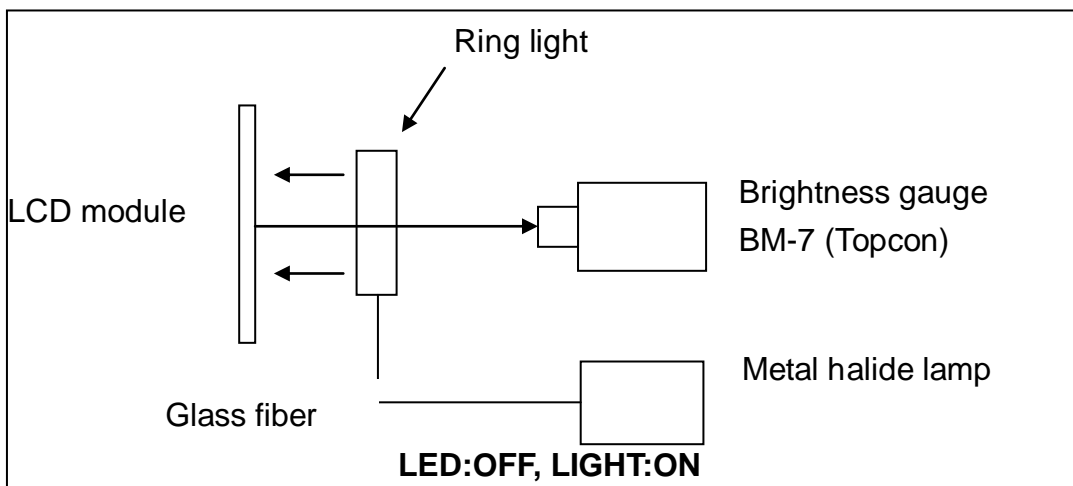

Note 8: The Uniformity definition
 $(\text{Min Brightness} / \text{Max Brightness}) \times 100\%$

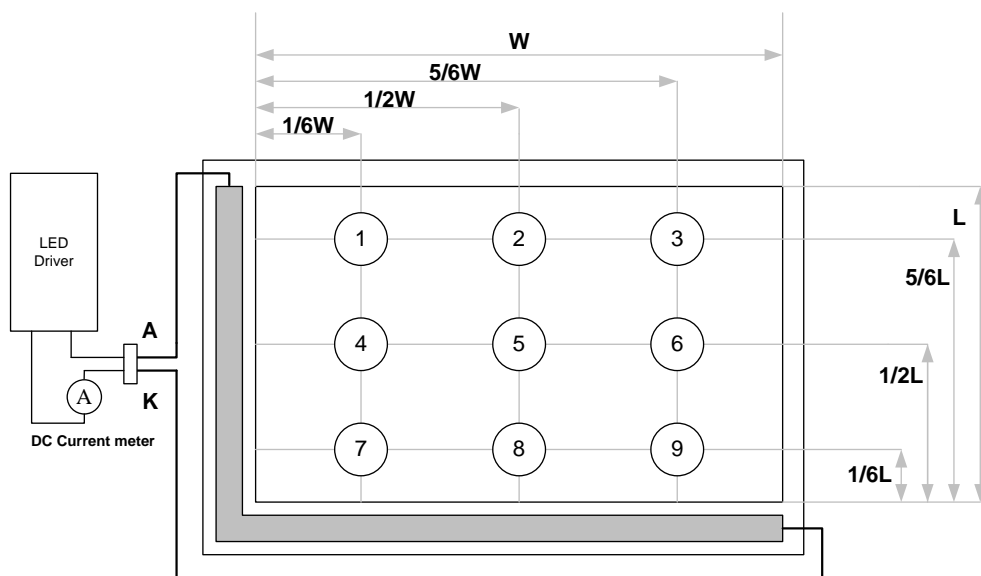

5 Interface specifications

5.1 Driving signals for the TFT panel

Pin no	Symbol	I/O	Description	Remark
1	GND		Gound	
2	CK		Clock signal. Latching data at the rising edge	
3	Hsync		Horizontal sync input in digital RGB mode	
4	Vsync		Vertical sync input in digital RGB mode	
5	GND	I	Gound	
6	R0	I	Red data	
7	R1	I		
8	R2	I		
9	R3	I		
10	R4	I		
11	R5	I		
12	GND	I	Gound	
13	G0	I	Green data	
14	G1	I		
15	G2	I		
16	G3	I		
17	G4	I		
18	G5	I		
19	GND	I	Gound	
20	B0	I	Blue data	
21	B1	I		
22	B2	I		
23	B3			
24	B4	I		
25	B5	I		
26	GND	I	Gound	
27	ENAB	I	Input data enable control	
28	VCC	I	+3.3V Power Supply	
29	VCC	I		
30	R/L	I	Scan direction R/L=H Left to Right R/L=L Right to Left	Note 1
31	U/D	I	Scan direction U/D=H Top to Bottom U/D=L Bottom to Top	Note 1
32	NC	I	Not use	
33	GND	I	Gound	

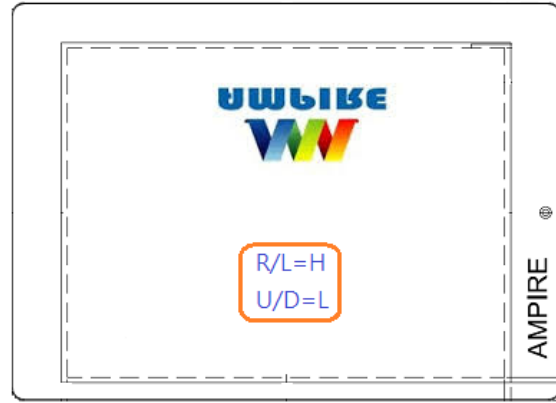
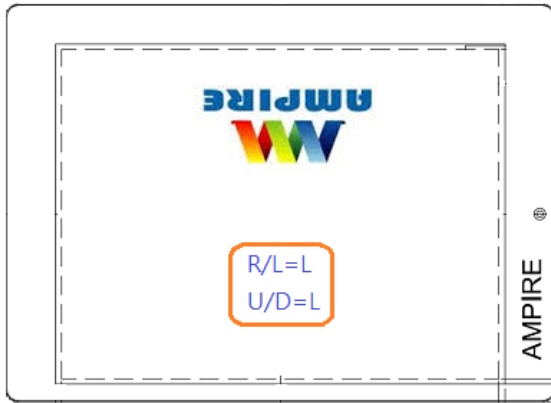
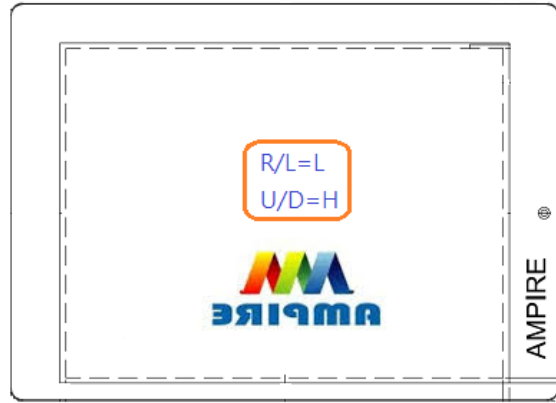
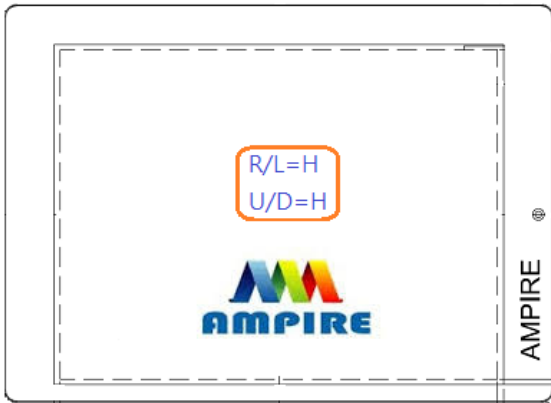

6 BLOCK DIAGRAM

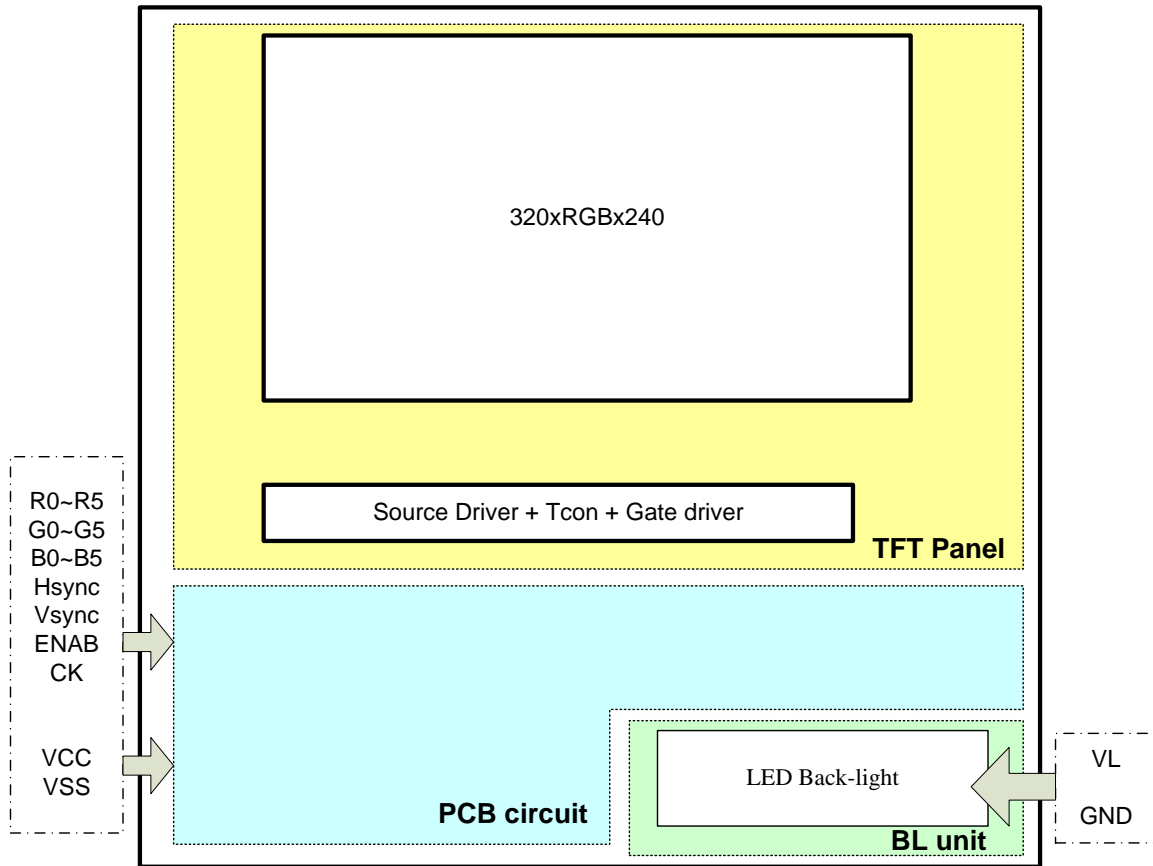

7 DISPLAYED COLOR AND INPUT DATA

	Color & Gray Scale	DATA SIGNAL																	
		R5	R4	R3	R2	R1	R0	G5	G4	G3	G2	G1	G0	B5	B4	B3	B2	B1	B0
Basic Color		0	0	0	0	0	0	0	0	0	0	0	0	0	0	0	0	0	0
	Red(0)	1	1	1	1	1	1	0	0	0	0	0	0	0	0	0	0	0	0
	Green(0)	0	0	0	0	0	0	1	1	1	1	1	1	0	0	0	0	0	0
	Blue(0)	0	0	0	0	0	0	0	0	0	0	0	0	1	1	1	1	1	1
	Cyan	0	0	0	0	0	0	1	1	1	1	1	1	1	1	1	1	1	1
	Magenta	1	1	1	1	1	1	0	0	0	0	0	0	1	1	1	1	1	1
	White	1	1	1	1	1	1	1	1	1	1	1	1	1	1	1	1	1	1
Red	Black	0	0	0	0	0	0	0	0	0	0	0	0	0	0	0	0	0	0
	Red(62)	0	0	0	0	0	1	0	0	0	0	0	0	0	0	0	0	0	0
	Red(61)	0	0	0	0	0	1	0	0	0	0	0	0	0	0	0	0	0	0
	:	:	:	:	:	:	:	:	:	:	:	:	:	:	:	:	:	:	:
	Red(31)	0	1	1	1	1	1	0	0	0	0	0	0	0	0	0	0	0	0
	:	:	:	:	:	:	:	:	:	:	:	:	:	:	:	:	:	:	:
	Red(1)	1	1	1	1	1	0	0	0	0	0	0	0	0	0	0	0	0	0
Green	Red(0)	1	1	1	1	1	1	0	0	0	0	0	0	0	0	0	0	0	0
	Black	0	0	0	0	0	0	0	0	0	0	0	0	0	0	0	0	0	0
	Green(62)	0	0	0	0	0	0	0	0	0	0	0	1	0	0	0	0	0	0
	Green(61)	0	0	0	0	0	0	0	0	0	0	1	0	0	0	0	0	0	0
	:	:	:	:	:	:	:	:	:	:	:	:	:	:	:	:	:	:	:
	Green(31)	0	0	0	0	0	0	0	1	1	1	1	0	0	0	0	0	0	0
	:	:	:	:	:	:	:	:	:	:	:	:	:	:	:	:	:	:	:
Blue	Green(1)	0	0	0	0	0	0	1	1	1	1	0	0	0	0	0	0	0	0
	Green(0)	0	0	0	0	0	0	1	1	1	1	1	0	0	0	0	0	0	0
	Black	0	0	0	0	0	0	0	0	0	0	0	0	0	0	0	0	0	0
	Blue(62)	0	0	0	0	0	0	0	0	0	0	0	0	0	0	0	0	0	1
	Blue(61)	0	0	0	0	0	0	0	0	0	0	0	0	0	0	0	0	0	1
	:	:	:	:	:	:	:	:	:	:	:	:	:	:	:	:	:	:	:
	Blue(31)	0	0	0	0	0	0	0	0	0	0	0	0	0	1	1	1	1	1
Blue	:	:	:	:	:	:	:	:	:	:	:	:	:	:	:	:	:	:	:
	Blue(1)	0	0	0	0	0	0	0	0	0	0	0	1	1	1	1	1	0	
	Blue(0)	0	0	0	0	0	0	0	0	0	0	0	1	1	1	1	1	1	

8 TOUCH PANEL ELECTRICAL SPECIFICATION

8.1 Touch Screen Panel Characteristics

1. Life Time : > 1,000,000 times
2. Linearity : $\leq 1.5\%$ after environmental & life test $\leq 3.0\%$
3. TOP ITO Film : Anti-Glare Hard Coating & Anti-Newton Ring
Sheet Resistance : 200~900 Ω ;
BOTTOM GLASS : Sheet Resistance : 200~900 Ω
4. Tai Type : FPC Gold-plated
5. Meet for ROHS.
6. Insulating Resistance : More than 20M Ω at DC 25 V
7. Active Force : $\leq 45g\sim 110g$. (Stylus or Finger or Similar)
8. Waterproof: Not damaged by running water applied to active area.
9. Surface Hardness : $\geq 3H$.

8.2 Touch Screen Pane & Interface

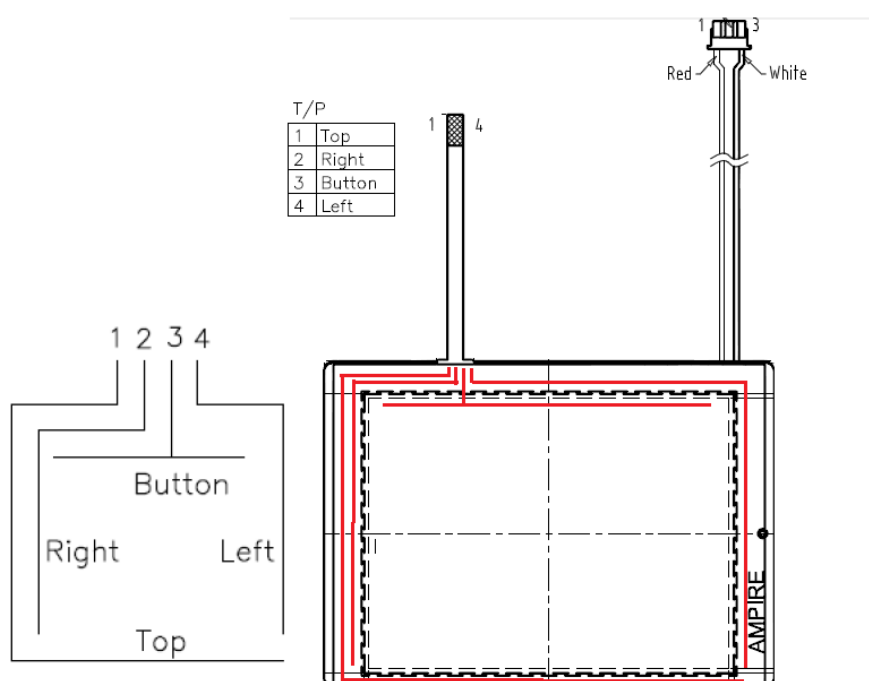

Pin No.	Symbol	Function
1	Top	Top electrode – differential analog
2	Right	Left electrode – differential analog
3	Bottom	Bottom electrode – differential analog
4	Left	Right electrode – differential analog

Note: Avoid operating with hard or sharp material such as ballpoint pen or a mechanical pencil except a polyacetal pen (tip R0.8mm or less) or a finger.

9 RELIABILITY TEST ITEMS

Test Item	Test Conditions	Note
High Temperature Operation	70±3°C , t=240 hrs	
Low Temperature Operation	-20±3°C , t=240 hrs	
High Temperature Storage	80±3°C , t=240 hrs	1,2
Low Temperature Storage	-30±3°C , t=240 hrs	1,2
Thermal Shock Test	-20°C ~ 25°C ~ 70°C 30 min. 5 min. 30 min. (1 cycle) Total 5 cycle	1,2
Humidity Test	40 °C, Humidity 90%, 96 hrs	1,2
Vibration Test (Packing)	Sweep frequency : 10 ~ 55 ~ 10 Hz/1min Amplitude : 0.75mm Test direction : X.Y.Z/3 axis Duration : 30min/each axis	2

Note 1: Condensation of water is not permitted on the module.

Note 2: The module should be inspected after 1 hour storage in normal conditions (15-35°C, 45-65%RH).

Note 3: The module shouldn't be tested more than one condition, and all the test conditions are independent.

Note 4: All the reliability tests should be done without protective film on the module.

Definitions of life end point :

- Current drain should be smaller than the specific value.
- Function of the module should be maintained.
- Appearance and display quality should not have degraded noticeably.
- Contrast ratio should be greater than 50% of the initial value.

10 USE PRECAUTIONS

10.1 HANDLING PRECAUTIONS

- (1) An LCD module is a fragile item and should not be subjected to strong mechanical shocks.
- (2) Avoid applying pressure to the module surface. This will distort the glass and cause a change in colour.
- (3) Under no circumstances should the position of the bezel tabs or their shape be modified.
- (4) Do not modify the display PCB in either shape or positioning of components.
- (5) Do not modify or move location of the zebra or heat seal connectors.
- (6) The device should only be soldered to during interfacing. Modification to other areas of the board should not be carried out.
- (7) In the event of LCD breakage and resultant leakage of fluid do not inhale, ingest or make contact with the skin. If contact is made rinse immediately.
- (8) When cleaning the module use a soft damp cloth with a mild solvent, such as Isopropyl or Ethyl alcohol. The use of water, ketone or aromatic is not permitted.
- (9) Prior to initial power up input signals should not be applied.
- (10) Protect the module against static electricity and observe appropriate anti-static precautions.

10.2 Installing precautions

- 1) The PCB has many ICs that may be damaged easily by static electricity. To prevent breaking by static electricity from the human body and clothing, earth the human body properly using the high resistance and discharge static electricity during the operation. In this case, however, the resistance value should be approx. $1M\Omega$ and the resistance should be placed near the human body rather than the ground surface. When the indoor space is dry, static electricity may occur easily so be careful. We recommend the indoor space should be kept with humidity of 60% or more. When a soldering iron or other similar tool is used for assembly, be sure to earth it.
- 2) When installing the module and ICs, do not bend or twist them. Failure to do so may crack LC element and cause circuit failure.
- 3) To protect LC element, especially polarizing plate, use a transparent protective plate (e.g., acrylic plate, glass etc) for the product case.

- 4) Do not use an adhesive like a both-side adhesive tape to make LCD surface (polarizing plate) and product case stick together. Failure to do so may cause the polarizing plate to peel off.

10.3 Storage precautions

- 1) Avoid a high temperature and humidity area. Keep the temperature between 0°C and 35°C and also the humidity under 60%.
- 2) Choose the dark spaces where the product is not exposed to direct sunlight or fluorescent light.
- 3) Store the products as they are put in the boxes provided from us or in the same conditions as we recommend.

10.4 Operating precautions

- 1) Do not boost the applied drive voltage abnormally. Failure to do so may break ICs. When applying power voltage, check the electrical features beforehand and be careful. Always turn off the power to the LC module controller before removing or inserting the LC module input connector. If the input connector is removed or inserted while the power is turned on, the LC module internal circuit may break.
- 2) The display response may be late if the operating temperature is under the normal standard, and the display may be out of order if it is above the normal standard. But this is not a failure; this will be restored if it is within the normal standard.
- 3) The LCD contrast varies depending on the visual angle, ambient temperature, power voltage etc. Obtain the optimum contrast by adjusting the LC drive voltage.
- 4) When carrying out the test, do not take the module out of the low-temperature space suddenly. Failure to do so will cause the module condensing, leading to malfunctions.
- 5) Make certain that each signal noise level is within the standard (L level: 0.2V_{dd} or less and H level: 0.8V_{dd} or more) even if the module has functioned properly. If it is beyond the standard, the module may often malfunction. In addition, always connect the module when making noise level measurements.
- 6) The CMOS ICs are incorporated in the module and the pull-up and pull-down function is not adopted for the input so avoid putting the input signal open while the power is ON.
- 7) The characteristic of the semiconductor element changes when it is exposed

to light emissions, therefore ICs on the LCD may malfunction if they receive light emissions. To prevent these malfunctions, design and assemble ICs so that they are shielded from light emissions.

- 8) Crosstalk occurs because of characteristics of the LCD. In general, crosstalk occurs when the regularized display is maintained. Also, crosstalk is affected by the LC drive voltage. Design the contents of the display, considering crosstalk.

10.5 Other

- 1) Do not disassemble or take the LC module into pieces. The LC modules once disassembled or taken into pieces are not the guarantee articles.
- 2) Do not keep the LCD at the same display pattern continually. The residual image will happen and it will damage the LCD. Please use screen saver
- 3) AMIPRE will provide one year warranty for all products and three months warrantee for all repairing products.

11 OUTLINE DIMENSION

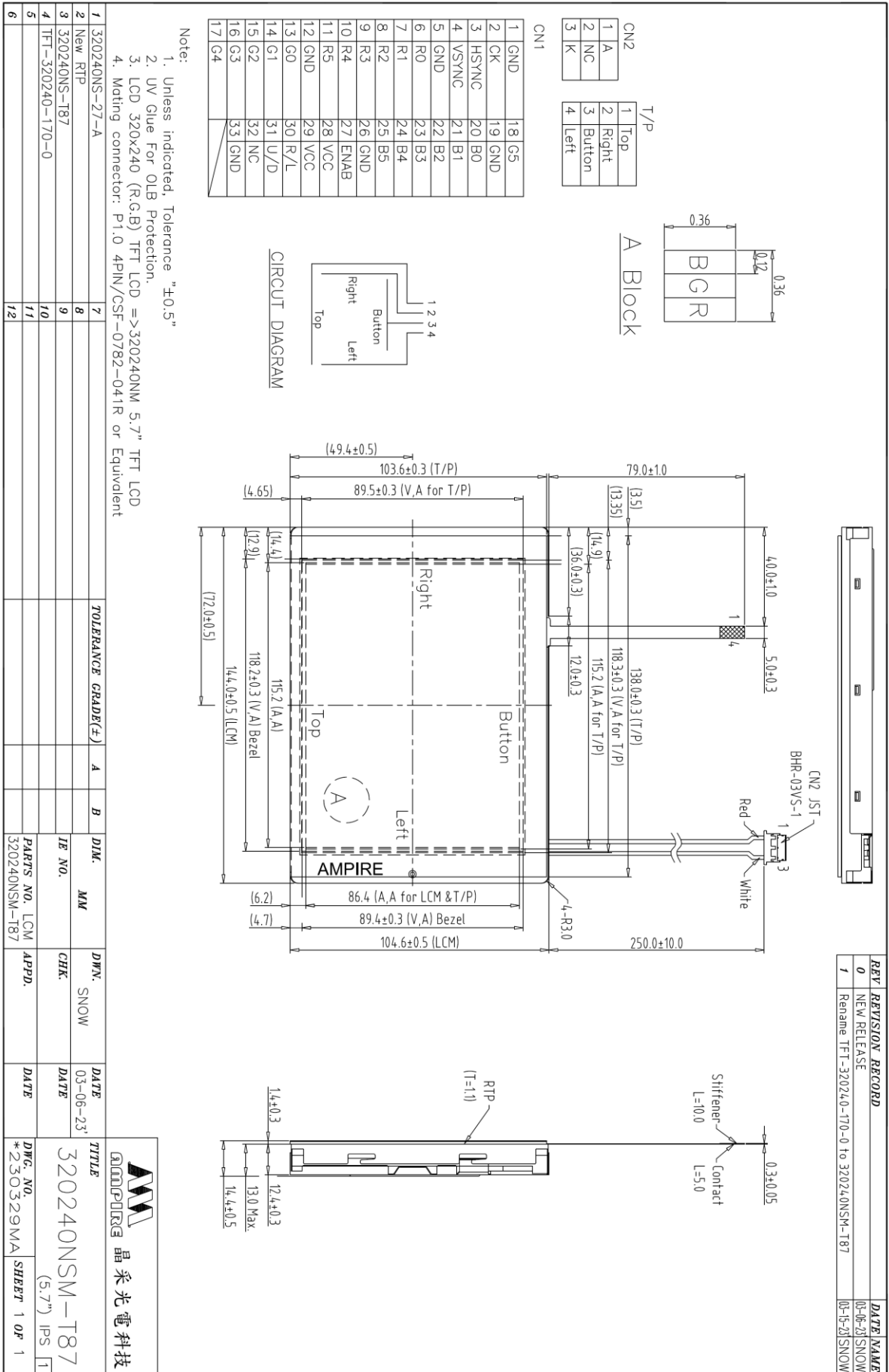

1	Rename TFT-320240-170-0 to 320240NSM-187	03-15-23	SNOW	REV	REVISION RECORD	03-06-23	SNOW	DATE NAME
0					NEW RELEASE			

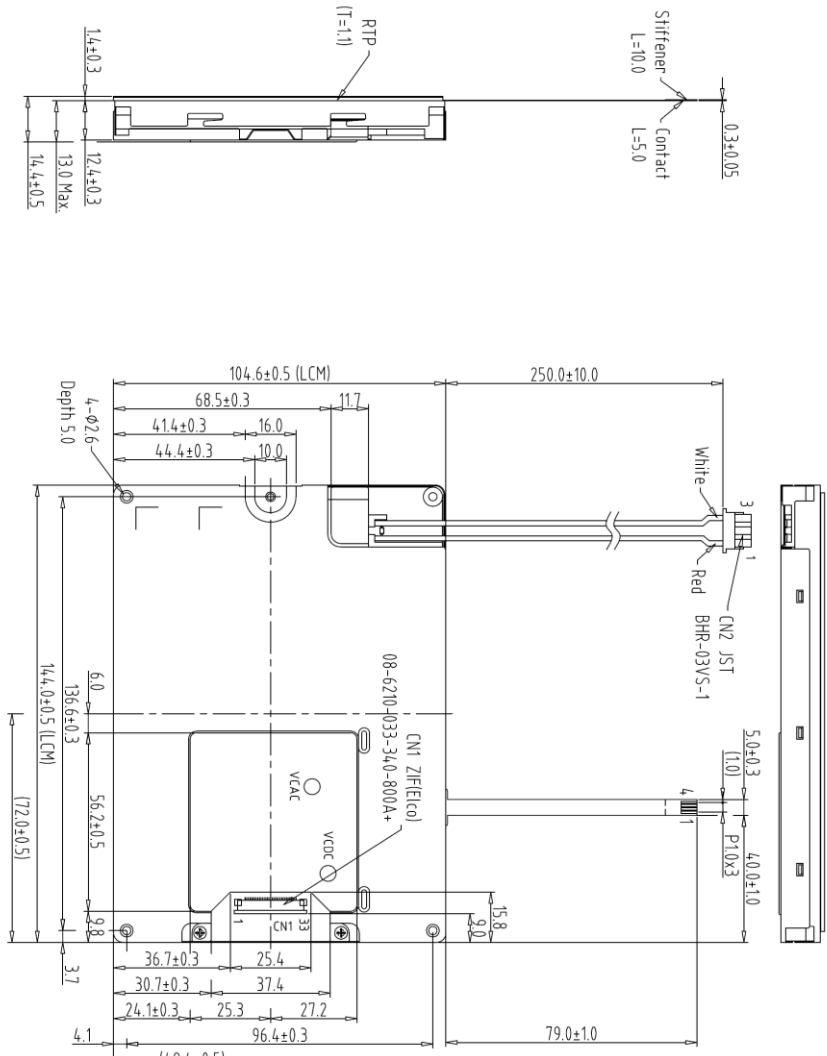

T/P	
1	Button
2	Left
3	Top
4	Right

CN2	
1	A
2	NC
3	K

CN1	
1	GND
2	CK
3	HSYNC
4	VSYNC
5	GND
6	R0
7	R1
8	R2
9	R3
10	R4
11	R5
12	GND
13	G0
14	G1
15	G2
16	G3
17	G4

Note:

1. Unless indicated, Tolerance "±0.5"
2. UV Glue For OLB Protection.
3. Main LCD 320x240 (R,G,B) TFT LCD => 5.7" TFT LCD
4. Mating connector: P1.0 4Pin/CSF-0782-041R or Equivalent

1	320240NS-27-A	7		TOLERANCE GRADE(±)	A	B	DIM.	MM	DWN.	SNOW	DATE	03-06-23	TITLE	320240NSM-T87
2	New RTP	8					IE NO.		CHK.		DATE		DWG. NO.	230330MA
3	320240NS-187	9					PARTS NO. LCM-1	APPD.			DATE		SHEET	1 OP 1
4	TFT-320240-170-0	10					320240NSM-187							
5		11												
6		12												

REV	REVISION RECORD	DATE	NAME
0	NEW RELEASE	08-22-03	NINNY
1	Add 氣泡袋 or 金屬袋 & EPE PROTECT SHEET	08-24-03	MILLY
2	Modify the outer box printing	11-20-06	MILLY

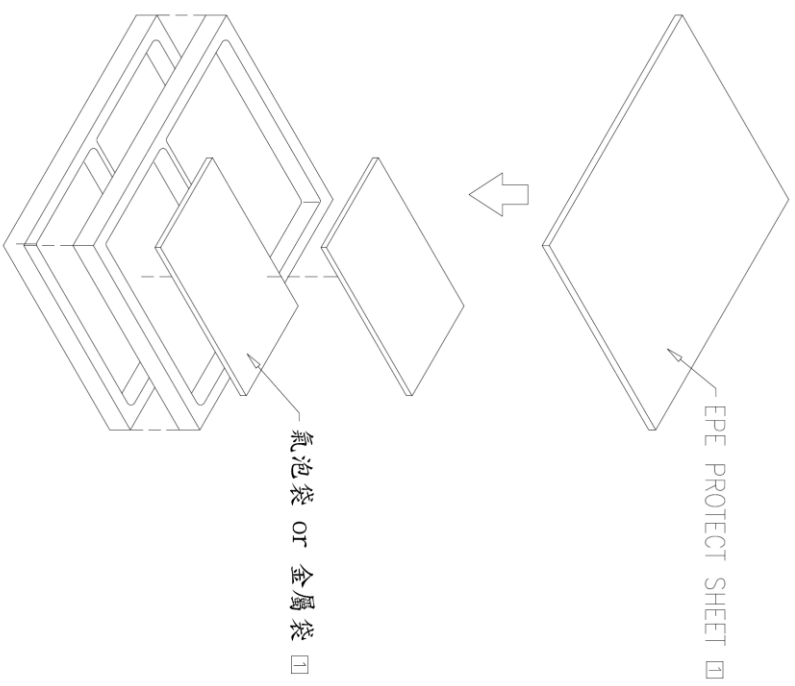

Note:
 1 Tray=1x2=2Pcs.
 2 Small Box=5xTray=10Pcs.(5 Tray)
 3 Big Box=4xSmall Box=40Pcs.

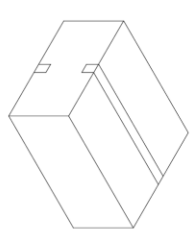

Small Box
 Size:LxWxH
 (267.0x224.0x124.0mm)

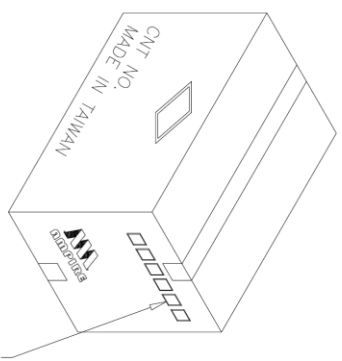

Big Box
 Size:LxWxH
 (491.0x300.0x295.0mm)
 (No.2)



	1	2	3	4	5	6	7	8	9	10	11	12									
TOLERANCE GRADE(±)							A	B	DIM.	MM	DWN.	NINNY	DATE	08-22-03	TITLE	240128B	DWG. NO.	*030832SC	SHEET	1 OP 1	
									IE NO.		CHK.		DATE								
									PARTS NO. BOX	240128B	APPD.		DATE								

