SLCD+ Controller Manual V1.2

January 26, 2011

For SLCD+ Hardware Revision A, RoHS Compliant

© Copyright Reach Technology Inc. 2003-2009
All Rights Reserved

Note: the software included with this product is subject to a license agreement as described in this Manual.

Reach Technology, Inc.
www.reachtech.com
(510) 770-1417
sales@reachtech.com

Table of Contents

0.	HARDWARE LIMITED WARRANTY AND SOFTWARE LICENSE AGREEMENT	5
0.1.	HARDWARE LIMITED WARRANTY	5
0.2.	RETURNS AND REPAIR POLICY	5
0.3.	SOFTWARE LICENSE AGREEMENT	6
1.	INTRODUCTION	8
1.1.	OVERVIEW	8
1.2.	FEATURES	8
1.3.	DIMENSIONS - REV G BOARD.....	9
1.4.	ELECTRICAL CHARACTERISTICS.....	10
1.5.	ENVIRONMENTAL.....	10
1.6.	PANEL SUPPORT	10
1.7.	UPGRADE OPTIONS.....	10
2.	CONFIGURATION GUIDE	11
2.1.	POWER	11
2.2.	SERIAL	11
2.3.	TFT PANEL ORIENTATION	11
2.4.	GROUNDING	11
3.	CONNECTORS AND JUMPERS.....	12
3.1.	J6 - POWER AND COM0 (RS232 COMMUNICATIONS MODE)	12
3.2.	J4 – COM2 RS232 PORT	13
3.3.	J5 – POWER AND COM3 3.3V / 5V PORT	13
3.4.	J12 - 4 WIRE TOUCH	14
3.5.	J11 - 4 WIRE TOUCH	14
3.6.	J2A - 4 WIRE TOUCH*.....	14
3.7.	J7 - 20 PIN 0.5MM FLAT FLEX LCD CONNECTOR	15
3.8.	J8 - 16 PIN 1MM FLAT FLEX LCD CONNECTOR	15
3.9.	J9 - 33 PIN 0.5MM FLAT FLEX LCD CONNECTOR	15
3.10.	J10 - BACKLIGHT / INVERTER CONTROL	16
3.11.	JP1 – COM1 / PROGRAMMING HEADER.....	16
4.	SYSTEM OVERVIEW	17
4.1.	GENERAL SLCD+ CONTROLLER	17
4.2.	OVERVIEW - SLCD+ EVALUATION KITS	17
4.2.1.	GETTING STARTED	17
4.2.2.	CONNECTING THE KIT TO A PC.....	17
4.2.3.	DEVELOPING THE APPLICATION GUI WITH AN EMBEDDED CONTROLLER AS HOST	18
4.3.	POWERCOM4 BOARD.....	19
4.4.	POWERCOM4 SCHEMATIC	20
4.5.	KIT / POWERCOM4 OPERATIONAL NOTES.....	21
4.6.	COMMUNICATIONS INTERFACE.....	22
	<i>General</i>	22
4.7.	LED INDICATORS	22
5.	SOFTWARE COMMAND REFERENCE.....	23

APPENDIX A - PANELS COMPATIBLE WITH THE SLCD+ CONTROLLER	24
A.1 HITACHI SX14Q001[-ZZA] AND SX14Q004[-ZZA]	24
A.2 HITACHI TX14D11VM1CAA-1 (CBA w/o TOUCH)	24
A.3 COLOR 5.7" CSTN KYOCERA KCG057QV1DC-G50	24
A.4 COLOR 5.7" TFT KYOCERA TCG057QV1AB-G00 OR TCG057QV1AA-G00	24
A.5 COLOR 5.5" TFT NEC NL3224BC35-20	24
A.6 COLOR 5.7" CSTN OPTREX F-51900NFU-FW-AC	24
A.7 COLOR 5.7" TFT SHARP LQ057Q3DC02	25
A.8 COLOR TFT SHARP SMALL	25
APPENDIX B - PARTS AND SUPPLIERS FOR SLCD+ CONTROLLER CONNECTIONS	
.....	26
B.1 CONNECTORS AND CABLES FOR J6, J10	26
B.2 CABLES FOR J7, J9	26
B.3 DISCRETE WIRE CABLE VENDORS	26
APPENDIX C - ORDERING INFORMATION.....	27
C.1 CONTACT REACH DIRECTLY FOR ORDERING INFORMATION.....	27
APPENDIX D - TROUBLESHOOTING	28
D.1 TOUCH UNRELIABLE OR NON-OPERATIVE.....	28
D.2 COLOR STN (PASSIVE) DISPLAY LOOKS TOO DARK, TEXT IS BLUE INSTEAD OF BLACK. .	28
APPENDIX E – USING COM0 / J6 FOR 3.3V CMOS INTERFACE.....	29
<i>COM0 Logic Level Mode:</i>	29

Figures

FIGURE 1: REV G BOARD PHYSICAL DIMENSIONS (INCHES).....	9
FIGURE 2: CONNECTORS AND JUMPERS (J11 NOT INSTALLED)	12

0. Hardware Limited Warranty and Software License Agreement

0.1. *Hardware Limited Warranty*

REACH TECHNOLOGY, Inc. warrants its hardware products to be free from manufacturing defects in materials and workmanship under normal use for a period of one (1) year from the date of purchase from REACH. This warranty extends to products purchased directly from REACH or an authorized REACH distributor. Purchasers should inquire of the distributor regarding the nature and extent of the distributor's warranty, if any. REACH shall not be liable to honor the terms of this warranty if the product has been used in any application other than that for which it was intended, or if it has been subjected to misuse, accidental damage, modification, or improper installation procedures. Furthermore, this warranty does not cover any product that has had the serial number altered, defaced, or removed. This warranty shall be the sole and exclusive remedy to the original purchaser. In no event shall REACH be liable for incidental or consequential damages of any kind (property or economic damages inclusive) arising from the sale or use of this equipment. REACH is not liable for any claim made by a third party or made by the purchaser for a third party. REACH shall, at its option, repair or replace any product found defective, without charge for parts or labor. Repaired or replaced equipment and parts supplied under this warranty shall be covered only by the unexpired portion of the warranty. Except as expressly set forth in this warranty, REACH makes no other warranties, expressed or implied, nor authorizes any other party to offer any warranty, including any implied warranties of merchantability or fitness for a particular purpose. Any implied warranties that may be imposed by law are limited to the terms of this limited warranty. This warranty statement supercedes all previous warranties, and covers only the Reach hardware. The unit's software is covered by a separate license agreement.

0.2. *Returns and Repair Policy*

No merchandise may be returned for credit, exchange, or service without prior authorization from REACH. To obtain warranty service, contact the factory and request an RMA (Return Merchandise Authorization) number. Enclose a note specifying the nature of the problem, name and phone number of contact person, RMA number, and return address.

Authorized returns must be shipped freight prepaid to Reach Technology Inc. 4575 Cushing Parkway, Fremont, California 94538 with the RMA number clearly marked on the outside of all cartons. Shipments arriving freight collect or without an RMA number shall be subject to refusal. REACH reserves the right in its sole and absolute discretion to charge a 15% restocking fee, plus shipping costs, on any products returned with an RMA.

Return freight charges following repair of items under warranty shall be paid by REACH, shipping by standard ground carrier. In the event repairs are found to be non-warranty, return freight costs shall be paid by the purchaser.

0.3. Software License Agreement

PLEASE READ THIS SOFTWARE LICENSE AGREEMENT CAREFULLY BEFORE DOWNLOADING OR USING THE SOFTWARE .

This License Agreement (“Agreement”) is a legal contract between you (either an individual or a single business entity) and Reach Technology Inc. (“Reach”) for software referenced in this guide, which includes computer software and, as applicable, associated media, printed materials, and “online” or electronic documentation (the “Software”).

BY INSTALLING, COPYING, OR OTHERWISE USING THE SOFTWARE, YOU AGREE TO BE BOUND BY THE TERMS OF THIS AGREEMENT. IF YOU DO NOT AGREE TO THE TERMS OF THIS AGREEMENT, DO NOT INSTALL OR USE THE SOFTWARE. IF YOU HAVE PAID A FEE FOR THIS LICENSE AND DO NOT ACCEPT THE TERMS OF THIS AGREEMENT, REACH WILL REFUND THE FEE TO YOU PROVIDED YOU (1) DO NOT INSTALL THE SOFTWARE AND (2) RETURN ALL SOFTWARE, MEDIA AND OTHER DOCUMENTATION AND MATERIALS PROVIDED WITH THE SOFTWARE TO REACH TECHNOLOGY INC AT: REACH TECHNOLOGY INC., 4575 CUSHING PARKWAY, FREMONT, CALIFORNIA 94538.

Reach Technology Inc. ("Reach") and its suppliers grant to Customer ("Customer") a nonexclusive and nontransferable license to use the Reach software ("Software") in object code form on one or more central processing units owned or leased by Customer or otherwise embedded in equipment provided by Reach.

EXCEPT AS EXPRESSLY AUTHORIZED ABOVE, CUSTOMER SHALL NOT: COPY, IN WHOLE OR IN PART, SOFTWARE OR DOCUMENTATION; MODIFY THE SOFTWARE; REVERSE COMPILE OR REVERSE ASSEMBLE ALL OR ANY PORTION OF THE SOFTWARE; OR RENT, LEASE, DISTRIBUTE, SELL, OR CREATE DERIVATIVE WORKS OF THE SOFTWARE.

Customer agrees that aspects of the licensed materials, including the specific design and structure of individual programs, constitute trade secrets and/or copyrighted material of Reach. Customer agrees not to disclose, provide, or otherwise make available such trade secrets or copyrighted material in any form to any third party without the prior written consent of Reach. Customer agrees to implement reasonable security measures to protect such trade secrets and copyrighted material. Title to Software and documentation shall remain solely with Reach.

SOFTWARE LIMITED WARRANTY. Reach warrants that for a period of ninety (90) days from the date of shipment from Reach: (i) the media on which the Software is furnished will be free of defects in materials and workmanship under normal use; and (ii) the Software substantially conforms to its published specifications. Except for the foregoing, the Software is provided AS IS. This limited warranty extends only to Customer as the original licensee. Customer's exclusive remedy and the entire liability of Reach and its suppliers under this limited warranty will be, at Reach's option, repair, replacement, or refund of the Software. In no event does Reach warrant that the Software is error free or that Customer will be able to operate the Software without problems or interruptions.

This warranty does not apply if the software (a) has been altered, except by Reach, (b) has not been installed, operated, repaired, or maintained in accordance with instructions supplied by Reach, (c) has been subjected to abnormal physical or electrical stress, misuse, negligence, or accident, or (d) is used in ultrahazardous activities.

DISCLAIMER. EXCEPT AS SPECIFIED IN THIS WARRANTY, ALL EXPRESS OR IMPLIED CONDITIONS, REPRESENTATIONS, AND WARRANTIES INCLUDING, WITHOUT LIMITATION, ANY IMPLIED WARRANTY OF MERCHANTABILITY, FITNESS FOR A PARTICULAR PURPOSE, NONINFRINGEMENT OR ARISING FROM A COURSE OF DEALING, USAGE, OR TRADE PRACTICE, ARE HEREBY EXCLUDED TO THE EXTENT ALLOWED BY APPLICABLE LAW.

IN NO EVENT WILL REACH OR ITS SUPPLIERS BE LIABLE FOR ANY LOST REVENUE, ROFIT, OR DATA, OR FOR SPECIAL, INDIRECT, CONSEQUENTIAL, INCIDENTAL, OR PUNITIVE DAMAGES HOWEVER CAUSED AND REGARDLESS OF THE THEORY OF LIABILITY ARISING OUT OF THE USE OF OR INABILITY TO USE THE SOFTWARE EVEN IF REACH OR ITS SUPPLIERS HAVE BEEN ADVISED OF THE POSSIBILITY OF SUCH DAMAGES.

In no event shall Reach's or its suppliers' liability to Customer, whether in contract, tort (including negligence), or otherwise, exceed the price paid by Customer. The foregoing limitations shall apply even if the above-stated warranty fails of its essential purpose. SOME STATES DO NOT ALLOW LIMITATION OR EXCLUSION OF LIABILITY FOR CONSEQUENTIAL OR INCIDENTAL DAMAGES.

The above warranty DOES NOT apply to any beta software, any software made available for testing or demonstration purposes, any temporary software modules or any software for which Reach does not receive a license fee. All such software products are provided AS IS without any warranty whatsoever.

This License is effective until terminated. Customer may terminate this License at any time by destroying all copies of Software including any documentation. This License will terminate immediately without notice from Reach if Customer fails to comply with any provision of this License. Upon termination, Customer must destroy all copies of Software.

Software, including technical data, is subject to U.S. export control laws, including the U.S. Export Administration Act and its associated regulations, and may be subject to export or import regulations in other countries. Customer agrees to comply strictly with all such regulations and acknowledges that it has the responsibility to obtain licenses to export, re-export, or import Software.

This License shall be governed by and construed in accordance with the laws of the State of California, United States of America, as if performed wholly within the state and without giving effect to the principles of conflict of law. If any portion hereof is found to be void or unenforceable, the remaining provisions of this License shall remain in full force and effect. This License constitutes the entire License between the parties with respect to the use of the Software.

1. Introduction

1.1. Overview

The SLCD+ controller provides complete Graphical User Interface for embedded systems using QVGA or smaller LCD panels. Using the SLCD is simply the quickest way to generate a user interface without a lot of graphical programming. It has a small size to fit in space-constrained applications.

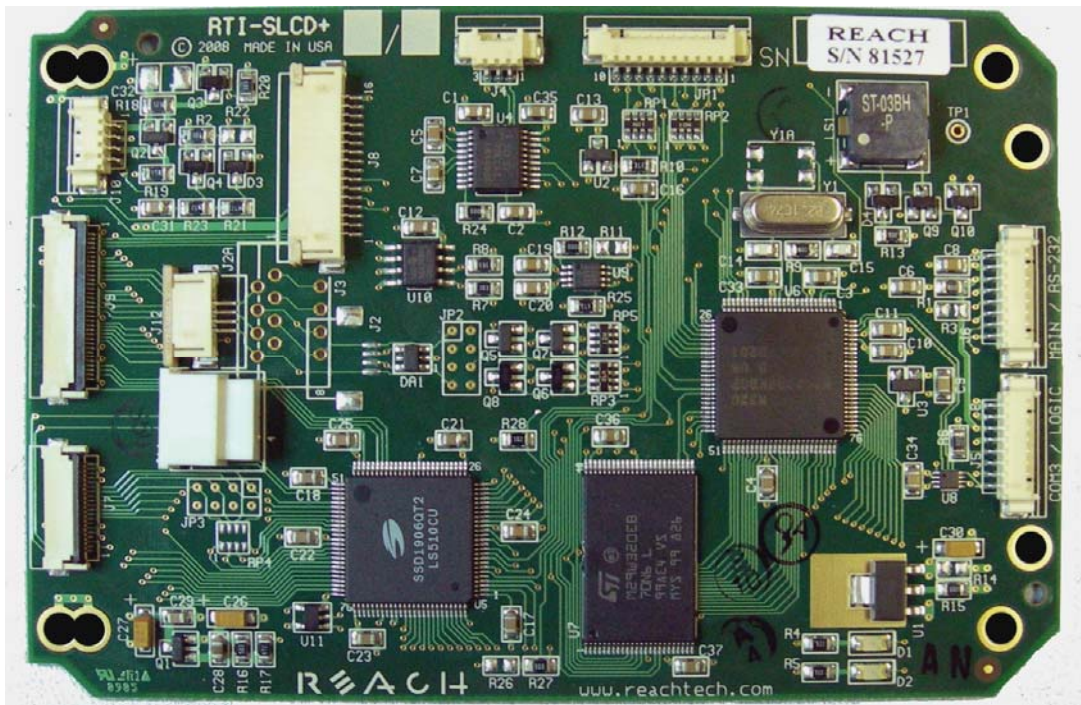

1.2. Features

- ◆ Drives either active (TFT) and passive (STN) displays
- ◆ Touch controller (4 wire resistive) on board
- ◆ Beeper for audible touch feedback and alarms
- ◆ 3" by 4.5" size, only 0.2" thick
- ◆ Low power (40mA typical at 5V)
- ◆ RS232 or TTL level interface up to 115200 baud
- ◆ User downloadable bitmaps with RLE compression (4MB of flash memory)
- ◆ Backlight enable and brightness control
- ◆ Reasonable cost
- ◆ Supports either landscape or portrait mode display (firmware option)
- ◆ Can be modified for specific OEM requirements
- ◆ RoHS Compliant as of Jan 1, 2007

1.3. Dimensions - Rev G board

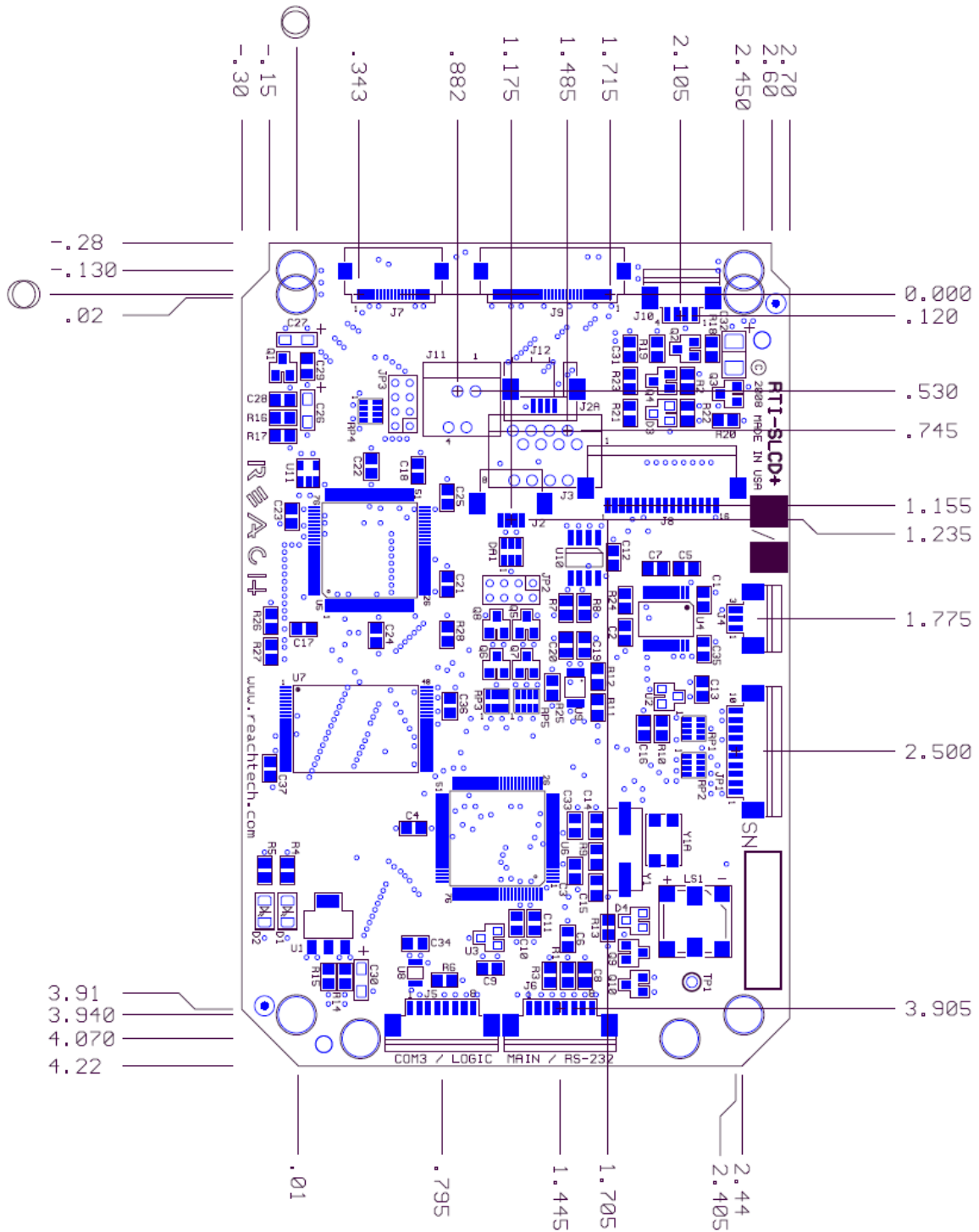

Figure 1: SLCD+ Rev A Board Physical Dimensions (inches)

1.4. **Electrical Characteristics**

The SLCD+ board takes in two voltages. One is simply passed through to the backlight inverter, and is typically either 5V or 12V. The SLCD+ itself requires 5V. *For other hardware options, contact Reach Technology Inc.*

The SLCD+ is designed for panels with VCC of 3.3V and built-in DC-DC converters and therefore do not need high positive or negative voltages. A list of compatible panels is provided in Appendix A.

Typical current draw is as follows:

State	mA
No panel attached, beeper quiet	40
No panel attached, beeper active	80

In general, the panel backlight power requirements dominate the power budget.

1.5. **Environmental**

The standard SLCD+ controller is rated for commercial temperature operation of 0 to 70°C. An industrial grade -40 to 85°C version is available as a special order. Note that most LCD panels have a limited operating temperature range of -20 to 70°C.

1.6. **Panel support**

The SLCD+ is factory programmed with panel configuration-specific firmware that includes panel type, orientation (landscape / portrait), backlight inverter control polarity, and touch panel orientation. Panel types include passive color (CSTN), or active matrix (TFT). Different commands and connection options may not apply depending on the firmware programmed on a given board. For example, there is contrast adjustment for passive panels but not for TFT panels. Please note that both landscape and portrait display modes cannot be supported by the same firmware; that is, the panel orientation cannot be changed “on-the-fly”. The firmware is in-system-upgradable to support different requirements and version upgrades.

1.7. **Upgrade options**

Reach has an upgrade to the SLCD+ that can provide more performance and supports larger panels. To provide for such an upgrade, the four mounting holes that are symmetric with respect to the board outline are recommended for use.

2. Configuration Guide

2.1. Power

Note: The standard configuration is for 5V power input and 3.3V panel power. For other configurations, please contact Reach.

2.2. Serial

The SLCD+ has four serial ports. Any can be used to send commands to the board. The ports and their characteristics are as follows:

Port	Description
COM0	Typically RS-232; remove a resistor for 3.3V CMOS logic level
COM1	3.3V CMOS logic only. Control signal (RTS) for RS485 driver enable
COM2	RS232 only
COM4	3.3V or 5V logic level I/O (on-board voltage translator)

COM0 is primarily used for RS232 communication, while COM1 supports 3.3V CMOS level signaling with RTS handshaking for an external transceiver such as RS485.

By default, serial communications is 115200 baud, 8 data bits, no parity, with 1 stop bit, with receive flow control via XON / XOFF. This can be changed by using a “power-on macro” which is described in the companion manual *SLCDx Software Reference*.

2.3. TFT Panel Orientation

The SLCD+ can support QVGA TFT panels with standard 33 pin flat flex pinouts. Some panels also have signals for display orientation, called Right/Left and Up/Down. These signals are controlled via the firmware using the “*orient” command. Refer to the *SLCDx Software Reference*.

2.4. Grounding

In order for the touch screen to work properly with a panel that has a CCFL backlight, the panel metal frame must be grounded to the SLCD+ ground. All SLCD+ mounting holes are connected to SLCD+ ground.

3. Connectors and Jumpers

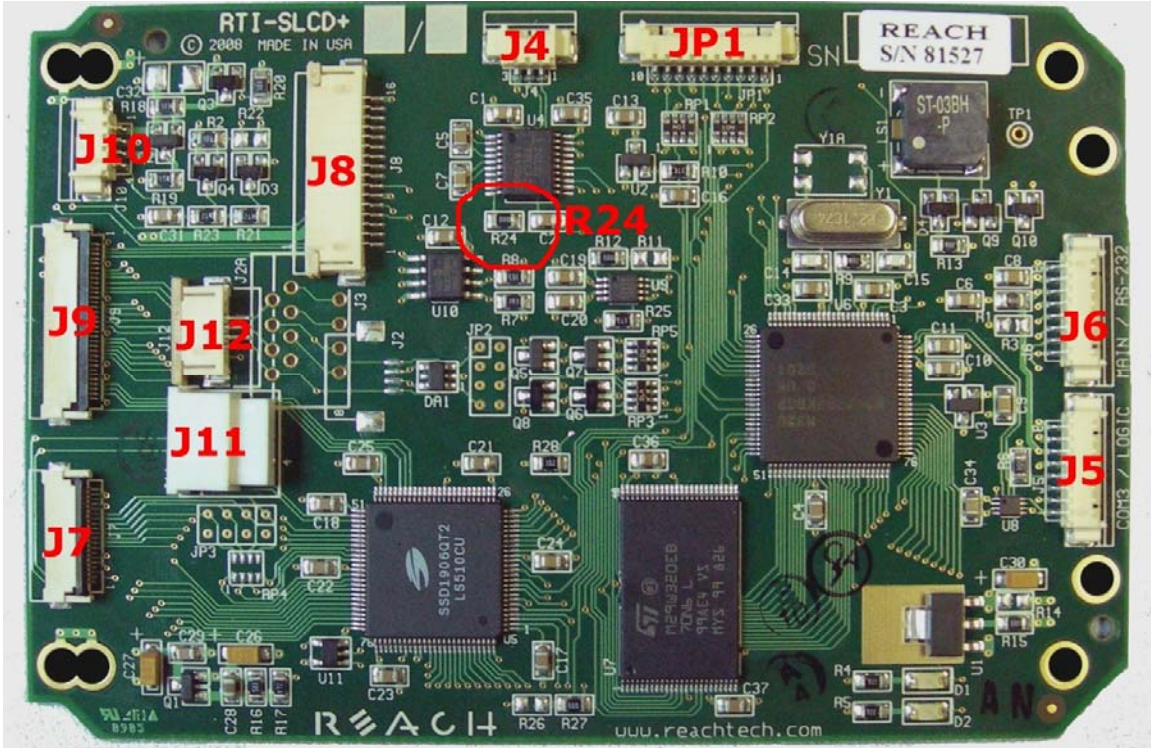

Figure 2: Connectors and Jumpers

3.1. J6 - Power and COM0 (RS232 communications mode)

J6 8 Pin Molex 53261-0871 for Power and Communications

Pin	RS232 Mode – R24 installed on board
1	do not connect
2	do not connect
3	RS232 input *
4	RS232 output
5	Backlight voltage (typ. 5V or 12V)
6	3.3V out (reference only)
7	5V Input
8	GND (power and communications)

* RS232 input valid only if R24 installed as zero ohms. This is the factory default.

Typical connection from a PC is as follows:

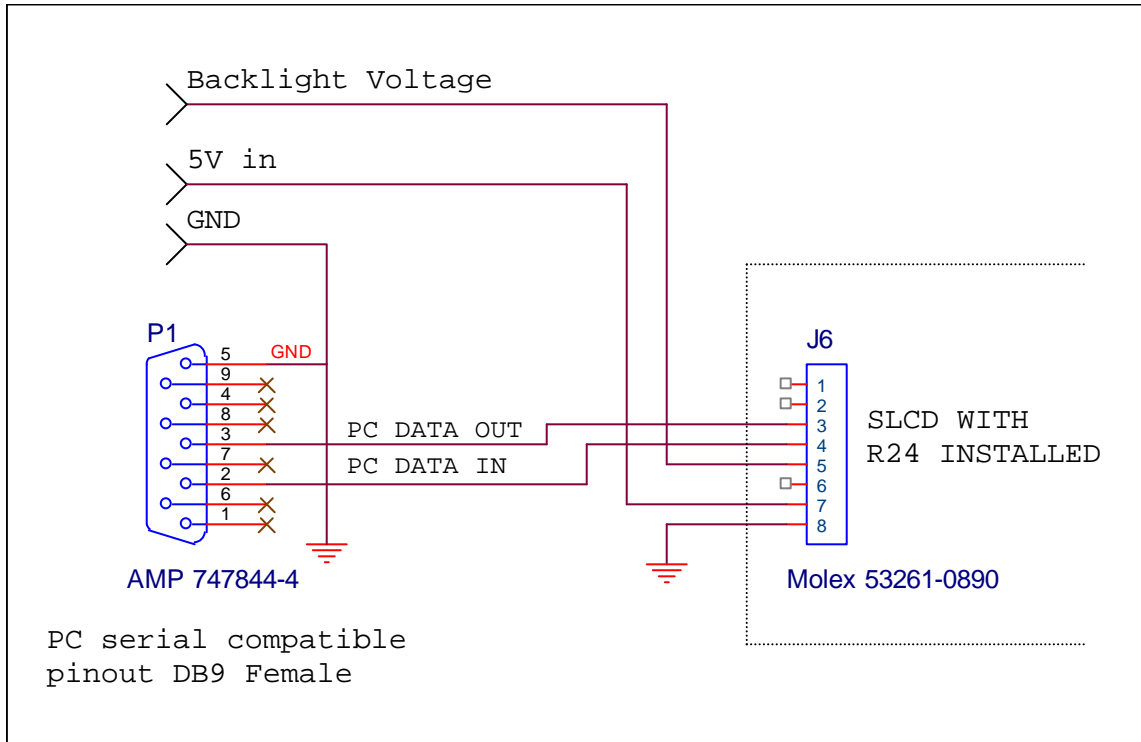

3.2. J4 – COM2 RS232 port

J4 3 Pin Molex 53261-0371 or equivalent

Pin	RS232 Mode – R24 installed on board
1	RS232 output
2	RS232 input
3	GND

3.3. J5 – Power and COM3 3.3V / 5V port

J6 8 Pin Molex 53261-0871 for Power and Communications

Pin	RS232 Mode – R24 installed on board
1	TxD (out)
2	RxD (in)
3	(Not connected)
4	R6 installed (default): 3.3V R6 removed: external I/O voltage 3.3V or 5V
5	Backlight voltage (typ. 5V or 12V)
6	3.3V out (reference only)*
7	5V Input
8	GND (power and communications)

♦ Can be set to GND via jumper if needed – check with Reach

3.4. J12 - 4 Wire Touch

J12 4 Pin Molex 52271-0469 or equivalent 1mm pitch bottom contact Zero-Insertion-Force Connector

<i>Pin</i>	<i>Signal</i>
1	X1 (left / right / up / down)*
2	Y1 (up / down / left / right)*
3	X2 (right / left / down / up)*
4	Y2 (down / up / right / left)*

* The sense of X and Y and up / down / right / left is determined by the touch calibration procedure – see “tc” command in the *SLCDx Software Reference Manual*.

3.5. J11 - 4 Wire Touch

J11 4 Pin Molex 39-51-3043 or equivalent 1.25mm pitch top contact Zero-Insertion-Force Connector

<i>Pin</i>	<i>Signal</i>
1	X1 (left / right / up / down)*
2	Y1 (up / down / left / right)*
3	X2 (right / left / down / up)*
4	Y2 (down / up / right / left)*

* The sense of X and Y and up / down / right / left is determined by the touch calibration procedure – see “tc” command in the *SLCDx Software Reference Manual*.

3.6. J2A - 4 Wire Touch*

J12 4 Pin Molex 22-05-3041 or equivalent 0.1" pitch 0.025" square post right angle friction latch Connector

<i>Pin</i>	<i>Signal</i>
1	X1 (left / right / up / down)*
2	Y1 (up / down / left / right)*
3	X2 (right / left / down / up)*
4	Y2 (down / up / right / left)*

* Normally not provided.

3.7. J7 - 20 pin 0.5mm Flat Flex LCD Connector

J7 20 Pin Omron XF2M-2015-1A or equivalent 0.5mm pitch Zero-Insertion-Force Connector

Pin	Signal	Pin	Signal
1	LCD Frame Pulse	11	LCD Data 4
2	LCD Line Pulse	12	LCD Data 3
3	LCD Clock	13	LCD Data 2
4	LCD Display On (DISPOFF-)	14	LCD Data 1
5	LCD VCC	15	LCD Data 0
6	GND	16	Contrast Control
7	Contrast Voltage	17	LCD VCC
8	LCD Data 7	18	LCD VCC
9	LCD Data 6	19	GND
10	LCD Data 5	20	GND

3.8. J8 - 16 pin 1mm Flat Flex LCD Connector

J8 16 Pin 52207-1685 or equivalent 1mm top contact Zero-Insertion-Force Connector

Pin	Signal	Pin	Signal
1	LCD Frame Pulse	9	LCD Data 1
2	LCD Line Pulse	10	LCD Data 2
3	LCD Clock	11	LCD Data 3
4	LCD Display On (DISPOFF-)	12	LCD Data 4
5	LCD VCC	13	LCD Data 5
6	GND	14	LCD Data 6
7	Contrast Voltage	15	LCD Data 7
8	LCD Data 0	16	GND

3.9. J9 - 33 pin 0.5mm Flat Flex LCD Connector

J9 33 Pin Omron XF2H-3315-1LW or equivalent 0.5mm pitch Zero-Insertion-Force Connector

Pin	Signal	Pin	Signal
1	GND	18	Green 5
2	LCD Clock	19	GND
3	LCD Line Pulse	20	Blue 0 (= Blue 4)
4	LCD Frame Pulse	21	Blue 1 (= Blue 5)
5	GND	22	Blue 2
6	Red 0 (= Red 4)	23	Blue 3
7	Red 1 (= Red 5)	24	Blue 4
8	Red 2	25	Blue 5
9	Red 3	26	GND
10	Red 4	27	LCD DE
11	Red 5	28	LCD VCC
12	GND	29	LCD VCC
13	Green 0 (= Green 4)	30	R/L (controlled by *orient cmd)
14	Green 1 (= Green 5)	31	U/D (controlled by *orient cmd)
15	Green 2	32	GND
16	Green 3	33	GND
17	Green 4		

3.10. J10 - Backlight / Inverter Control

J10 4 Pin Molex 53261-0471

Pin	Signal
1	Backlight power (connected to J6 pin 5)
2	Ground
3	Backlight on/off control; can also be used as PWM for dimming
4	Backlight brightness control

This connector is used to power and control the panel backlight. The sense of the on/off control (active high or low) is set in the firmware. The sense and range of the brightness voltage output is also set by the board firmware.

3.11. JP1 – COM1 / Programming Header

This connector is used for communicating using the COM1 serial port. It has a driver enable for use with RS485 transceivers. It also has a hardware reset signal for the SLCD+ processor.

JP1 10 Pin Molex 53261-1071

Pin	Signal
1	VCC (typ. 3.3V) – can be used to power external transceiver
2	DE (active high) – use if needed to enable external 422 / 485 driver
3	Do not use
4	RxD1 – Com1 input
5	Do not use
6	Do not use
7	GND
8	RESET- input; drive low to hardware reset the SLCD+ processor
9	Do not use
10	TxD1 – Com1 output

TxD1, RxD1, DE, RESET- electrical specifications:

Input voltage	-0.3 / VCC+.03	Absolute Min / Max
Input voltage	0.8xVCC	High min
Input voltage	0.2xVCC	Low max
Output current High	1mA	Min, Vout = 0.9xVCC
Output current Low	-1mA	Min, Vout = 0.1xVCC

4. System Overview

4.1. General SLCD+ Controller

The SCLD acts as a "smart terminal" and is generally connected to a host processor that implements the desired Graphical User Interface (GUI) by issuing commands to the SLCD+ and processing button press responses from the SLCD+. In this manual, the term "host" is used to describe the device connected to the SLCD+.

Please refer to the *SLCDx Software Reference Manual* for more detail.

4.2. Overview - SLCD+ Evaluation Kits

The SCLD+ is available in an evaluation kit form, and also as a complete enclosed unit. In the kit or enclosure, it comes pre-loaded with bitmaps and macros that implement a demo if the unit is powered on with the communications port looped back transmit to receive. This loopback is via external plug in the case of the enclosed unit, or via a jumper on the "PowerCom" board in the case of the unenclosed kit.

The SLCD+ evaluation kit comes with hardware and firmware options loaded for the specific panel supported by the kit. It also includes a two-port DB9 interface board that makes it easier to connect to external host systems. One port can be used to download bitmaps from a PC while the other connects to the "host" computer.

4.2.1. Getting Started

The SLCD+ kit as shipped contains a demo that allows you to verify its functionality. Plug the supplied power supply into the barrel connector on the triangular shaped PowerCom 4 board. The display should light up and lead you through various touch-activated screens.

4.2.2. Connecting the kit to a PC

The kit should be connected to a PC so that the serial command interface can be experimented with. This is a preliminary step before the unit is connected to the embedded system that will control the display in the embedded system. ***PLEASE NOTE: In order to communicate over the serial port, the Demo jumper JPI on the triangular PowerCom4 board must be removed.*** This jumper loops back transmit to receive on the serial port and this is what tells the SLCD+ to run the demo.

As shipped, the serial port is set to 115,200 baud, 8 bit, 1 start, 1 stop, no parity. There are two DB9 connectors on the "PowerCom 4" board. Connect the PC using a straight through cable to the DB9 marked "MAIN" (P1). A USB-to-serial adapter cable can also be used and plugged directly into this connector. *Note: the Belkin USB-serial adapter has software compatibility issues and is not recommended; Reach recommends either Prolific or FTDI chip based adapters.*

Once connected, use RealTerm (preferred), HyperTerminal, or similar terminal emulator to send and receive commands from the kit. HyperTerminal has limitations that can cause problems; specifically, some versions cannot send the "escape" character. We recommend RealTerm (shareware – Google “realterm” to download).

4.2.3. Developing the application GUI with an embedded controller as host

To develop the actual application, determine whether the host will interface via 3.3V or 5V CMOS levels or RS232 levels. Then connect the host accordingly to either J6 (232) or J5 (CMOS levels). Then connect the PC to either J6 or J4 whichever is not used. This way either the host or the PC can drive the SLCD+. Typically the PC is used to experiment and determine what command is needed for a graphical interface, and to download new bitmaps and macros without having to disconnect the embedded system.

How this dual port connection works is this: the SLCD+ has a non-volatile memory which remembers which port is the “main” control port. This is selected via the `*com0main` or `*com1main` command. The other port is then the aux port. When the aux port receives three <return> characters in a row, it switches to become the main port. This way, the PC can take control of the SLCD+ communications channel and send commands or download new bitmaps. Use the reset button to simulate a power-on event which restores the main port as the default control port, or use the `*prevCons` command.

4.3. PowerCom4 Board

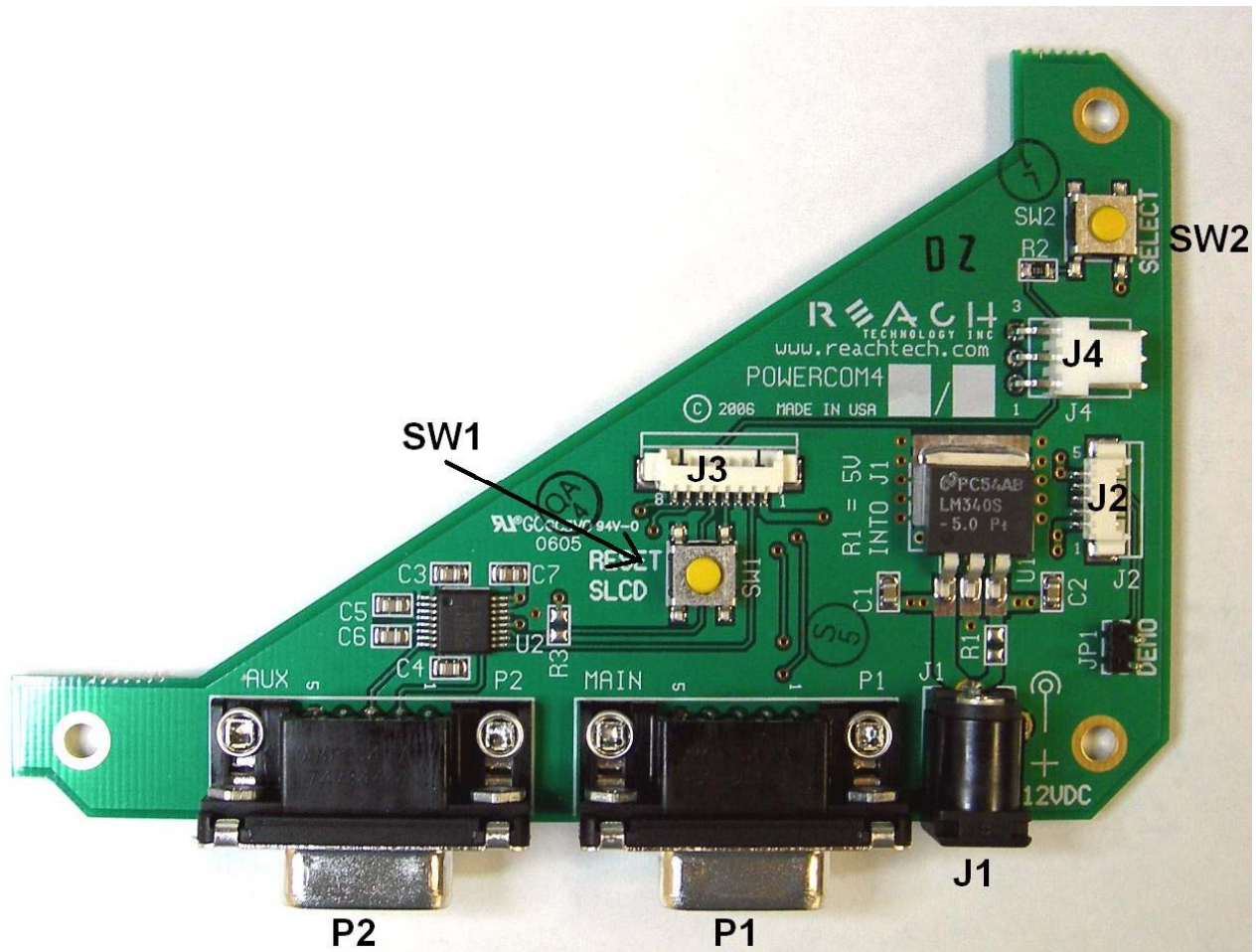

PowerCom4 Board

4.4. PowerCom4 Schematic

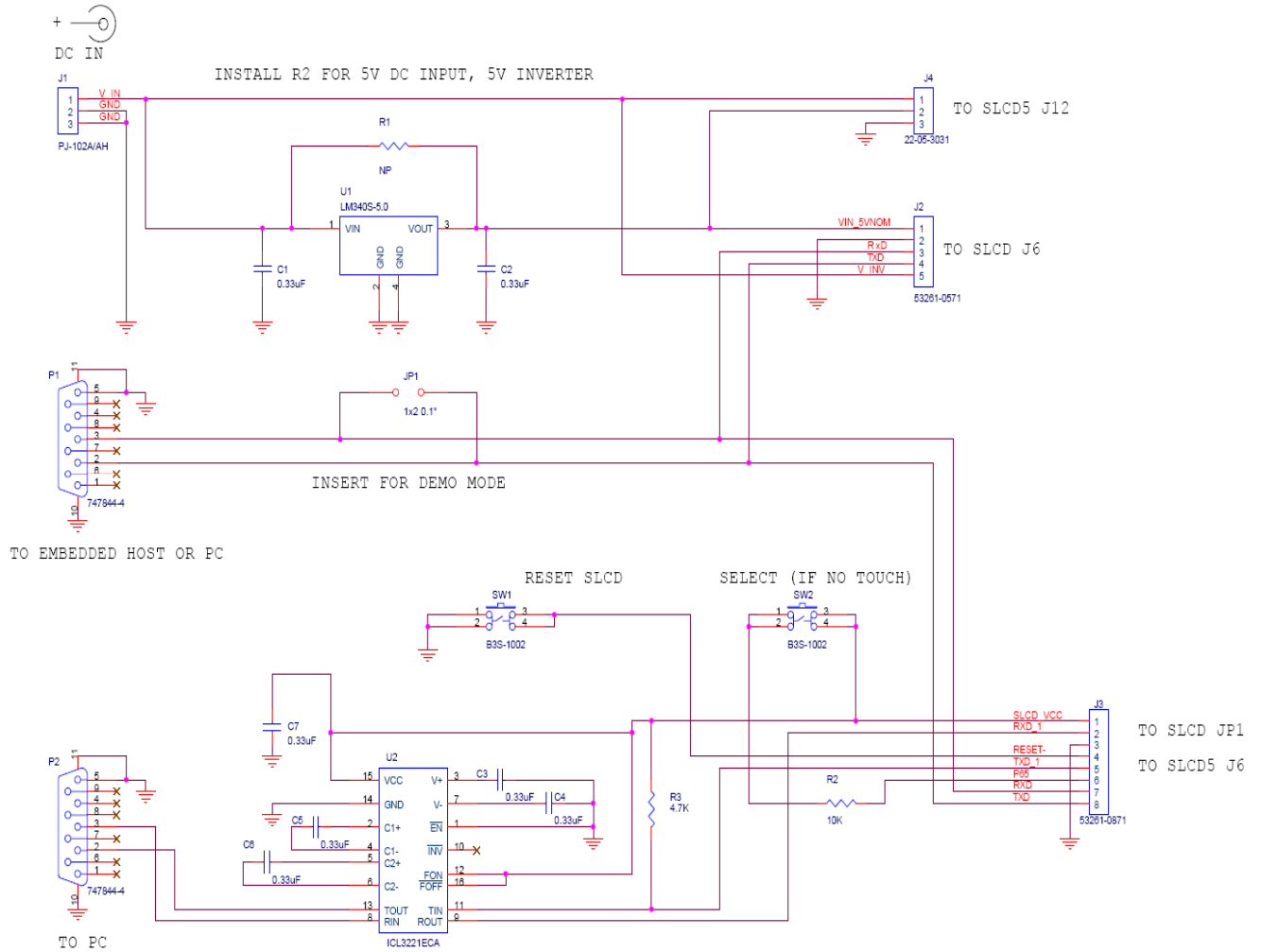

4.5. Kit / PowerCom4 Operational Notes

1. The unit default baud rate is 115200. The unit does not echo characters (for communications efficiency), so you must select "echo characters locally" or "half duplex" in your PC communications program. Also, all return strings are terminated by a <return> only, so you need to specify "add line feed to line return" as well.
2. The internal demo starts with an optional touch calibration. In order for the touch screen to work reliably ensure the LCD frame is grounded to the SLCD+ mounting holes.
3. The demo requires a certain set of bitmaps to be loaded. These are loaded as part of the kit. If these are not present, it will not run correctly. Copies of these are provided in the "BMPs and Macros" directory on the CD provided. Use the BMPload program and load the demo.lst and macros.mac files to restore the demo.
4. The SW1 "RESET" button on the PowerCom4 board resets the SLCD+ processor and performs the equivalent of a power-on reset.
5. The SW2 "SELECT" button on the PowerCom 4 board is intended for use with kits that don't have a touch screen, and is not implemented on a standard kit.
6. Jumper JP1 is the "DEMO" serial loopback jumper that is installed at the factory in order to automatically run the demo at power up. Remove the jumper prior to attempting serial communications with SLCD+ controller.
7. The J1 barrel connector is the external power supply connector for the development kit. For kits with 12VDC input it is 2.1mm, center pin positive. For 5VDC input kits it is 2.5mm center pin positive.
8. Connector J2 provides the communications path for the P1 "MAIN" RS232 serial port. It connects to J6 of the SLCD+ controller. Connector J2 also provides 5VDC power to the SLCD+ controller.
9. Connector J3 of the PowerCom4 board is the communications path for the P2 "AUX" rs232 serial port. It connects to JP1 of the SLCD+ controller. This provides the path for the "RESET", and "SELECT" signal buttons. As well as the communications path for downloading of bitmaps and macros to the SLCD+ controller.
10. Connector J4 is reserved for future use.

4.6. **Communications Interface**

General

- ◆ Default communication is at a baud rate of 115200 with no parity, software (XON/XOFF) flow control, 8 bits of data, and 1 stop bit. The baud rate can be set to a different initial value on power-on by using the POWER-ON MACRO feature.
- ◆ Characters are not echoed and all responses end only with a <return> character (0x0d). This is done to maximize communications line efficiency.
- ◆ ASCII commands consist of a command (one or more ASCII characters) followed by the data associated with that command, followed by a carriage return. In this manual, the return character (value 0x0D, decimal 13) is signified by <return>.
- ◆ Screen pixel values start at the upper left-hand corner. This is point x=0, y=0. The lower right corner is point x=319, y=239 (landscape mode).
- ◆ The maximum length of any command including the termination character is 127 characters.

4.7. **LED indicators**

The SLCD+ board has two LEDs to indicate operational status.

D2 is closest to the board edge. It turns on when power is applied and the microcontroller is operating correctly. It can also be turned off and on via the SET LED command.

D1 is lit while the SLCD+ is executing a command or running a looping macro. It is useful to determine the activity level of the SLCD+.

5. Software Command Reference

The software commands and utilities are described in a separate document, the *SLCDx Software Reference Manual*.

Appendix A - Panels compatible with the SLCD+ controller

The SLCD+ controller has been tested with the following panels:

A.1 *Hitachi SX14Q001[-ZZA] and SX14Q004[-ZZA]*

Color STN 5.7" (-ZZA for integrated touch screen)

3.3V operation

Plugs directly into SLCD+ J8

A.2 *Hitachi TX14D11VM1CAA-1 (CBA w/o touch)*

Color TFT 5.7", standard mounting, with or without touch

3.3V operation

Reach supplies a custom Flat Flex cable for SLCD+ J7

A.3 *Color 5.7" CSTN Kyocera KCG057QV1DC-G50*

Color STN 5.7" high brightness, integrated touch screen

3.3V operation

Plugs directly into SLCD+ J9 using standard 0.5mm 20 pin flat flex cable available from Reach or www.axoncable.com.

A.4 *Color 5.7" TFT Kyocera TCG057QV1AB-G00 or TCG057QV1AA-G00*

Color TFT 5.7" high brightness, integrated touch screen (AB)

3.3V operation

Plugs directly into SLCD+ J9 using 33 pin flat flex cable available from Reach or www.axoncable.com

A.5 *Color 5.5" TFT NEC NL3224BC35-20*

5.5" high brightness, industrial applications, long lifecycle (5 year) availability

3.3V operation

Plugs directly into SLCD+ J9 using 33 pin flat flex cable available from Reach or www.axoncable.com

A.6 *Color 5.7" CSTN Optrex F-51900NFU-FW-AC*

Color STN 5.7" low cost

3.3V operation

Requires custom flat flex cable from Reach

A.7 Color 5.7" TFT Sharp LQ057Q3DC02

Color TFT 5.7" high brightness

3.3V operation

Can use 3M touch screen

Plugs directly into SLCD+ J9 using 33 pin flat flex cable available from Reach or www.axoncable.com

A.8 Color TFT Sharp small

LQ038Q5DR01 - 3.8" high brite

LQ050Q5DR01 - 5.0" high brite

Quadrangle (<http://www.quadrangleproducts.com>) can supply the 33 pin flat flex adapter cable for these panels.

Appendix B - Parts and suppliers for SLCD+ controller connections

B.1 Connectors and cables for J6, J10

The board connector is Molex type 53261-0890 (J6) and 53261-0490 (J10). The mating connector is made of two parts: a receptacle housing and crimp pins. A special tool is needed to make the crimps. Alternatively, custom cables can be purchased. See B.3 for cable vendors.

J6, J5 Receptacle housing Molex P/N 51021-0800

J4 Receptacle housing Molex P/N 51021-0300

J10 Receptacle housing Molex P/N 51021-0400

Crimp pins Molex 50079 or 50058

Prototype (small qty) crimp tool Molex 63811-0200

Production crimp tool Molex 63811-0000

All of the above are available from www.digikey.com

B.2 Cables for J7, J9

These connectors attach to flat flex cables that then attach to the display unit. These cables can be ordered from either

www.axoncable.com or www.quadrangleproducts.com or www.digikey.com

B.3 Discrete wire cable vendors

The cables needed for any of the 1.25mm cables can be specified and supplied as assembled cables by:

www.intcomptech.com

or

Interconnect Marketing Solutions

thuynh@interconnectmarketing.com

Appendix C - Ordering information

C.1 Contact Reach directly for ordering information.

Reach Technology Inc
4575 Cushing Parkway
Fremont, California 94538
(510) 770-1417

Appendix D - Troubleshooting

D.1 *Touch unreliable or non-operative*

If the touch screen is unreliable or non-operative, do the following:

1. Make sure the metal shell of the display is connected to one of the SLCD+ mounting holes. This is the same as saying that the display case should be grounded to SLCD+ ground. Note that this only applies to displays with CCFL backlights not to EL or LED backlights.
2. Run the TOUCH CALIBRATE command, "tc". This will reset the calibration values and allow you to recalibrate the touch screen.

If after doing this the touch is still non-operative, check the touch connection into the SLCD+ board. Some touch panels use conductive ink that can be easily scraped off by too many or incorrect connector insertion cycles. If there are holes you can see through on the touch connector end where it plugs into the SLCD+ connector this is the problem.

To determine the accuracy and sensitivity of the touch, you can use the "debug" command as follows:

```
*debug 1<return>
```

This puts an "X" on the screen whenever a valid touch is recognized. To turn off, use:

```
*debug 0<return>
```

D.2 *Color STN (passive) display looks too dark, text is blue instead of black*

If the display does not look correct, it may be that the contrast has been set too far high or low. Use the "C=" command to set the contrast adjust at mid-point and the use the "C+" and "C-" commands to adjust the contrast for best color.

Appendix E – Using COM0 / J6 for 3.3V CMOS Interface

The SLCD+ serial port COM0 is typically used for communication using RS232 levels. However, by removing resistor R24, it can use 3.3V CMOS logic levels.

COM0 Logic Level Mode:

1. Resistor R24 (next to J6) must be removed.

Connector J6 in Logic Level Mode:

J6 8 Pin Molex 53261-0890 for Power and Communications

<i>Pin</i>	<i>Logic level mode – R24 not installed</i>
1	TxD- output from microcontroller.
2	RxD- input to microcontroller *
3	do not connect
4	do not connect
5	Backlight power (Typ. 12V) input
6	3.3V out (reference only)
7	5V Input
8	GND (power and communications)

- * R24 must be removed to avoid conflict with RS232 receiver.

Typical connection directly from a microcontroller is as follows:

